



2024

Fayette County 4-H Handbook



*Including information on
4-H policies, club membership and exhibit opportunities*

University of Illinois Extension

Fayette County Office

118 N. Sixth Street

Vandalia, IL 62471

Phone: 618-283-2753

Fax: 217-347-7775

<http://web.extension.illinois.edu/cefj/>



Illinois Extension

UNIVERSITY OF ILLINOIS URBANA-CHAMPAIGN



*University of Illinois · United States Department of Agriculture · Local Extension Councils Cooperating
University of Illinois Extension provides equal opportunities in programs and employment.
If you need a reasonable accommodation to attend, contact 618-283-2753. Early requests are strongly
encouraged to allow sufficient time to meet your access needs.*



Fayette County 4-H Handbook 2024

Dear 4-H Members, Leaders, and Parents:

The **2024 4-H Handbook** is provided to assist you in preparing for this year's 4-H fair. It identifies the 4-H projects, which may be exhibited, their various classes, and the rules and regulations governing exhibition. **Please read it thoroughly** and carefully to prevent any misunderstanding or potential disappointment. The **general rules and regulations** at the beginning of the book and the specific regulations under each project are important. All projects are listed in this book alphabetically.

Fayette Co. 4-H Fair Schedule -----	pg. 2
Schedule of Events -----	pg. 3
General 4-H Policies -----	pg. 4-5
Member Code of Conduct -----	pg. 6
Membership, Awards, & Records-----	pg. 7-9
4-H Show Policies & Regulations -----	pg. 10-12
4-H General Projects Show Check-In & Regulations-----	pg. 13-14
General Project Exhibit Table of Contents -----	pg. 15
General Project Exhibit Information -----	pg. 16-65
Cloverbuds Project Show Information-----	pg. 66
Livestock Exhibits, Shows & Regulations -----	pg. 64-67
Auction Rules & Regulations -----	pg. 68-69
Livestock Animal Show information -----	pg. 70-87

Registration of fair entries must be done using **Fair Entry:**
<https://fayette4-hfair.fairentry.com>

DEADLINE TO ENTER: BY Midnight June 1, 2024.

Thank you for your cooperation. We look forward to working with you for another successful Fayette County 4-H Fair. If you have questions, contact the Fayette County Extension office at 618-283-2753.

Sincerely,

Unit 21 Extension
Fayette County Extension Staff



Fayette County 4-H

2024 Fair Schedule

July 11th - 16th

Tuesday, April 2nd

5:00 PM Fayette County 4-H Public
Speaking Contest

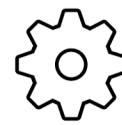
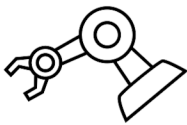

Saturday, June 15th

9-11 AM Fayette County Fairgrounds
Clean Up

Thursday, July 11th

12:30 PM Check-in opens for assigned
clubs

1-3 PM General Projects
Location - Under Pavilion

Friday, July 12th

1:30 PM Dog Show Check-In

2 PM Dog Show

3:30 PM Cat Show Check-In

4 PM Cat Show

5:30 PM 4-H General Project Awards
Location - Show Ring

Saturday, July 13th

7 AM Horse Check-In

8 AM Horse Show

12:00 PM Livestock must be on grounds

12:30 PM Mandatory Livestock Meeting
Location - Show Ring

2:30 PM Rabbit Check-In

3 PM Rabbit Show

5 PM Goat/Swine Check-In/Weigh-In

Sunday, July 14th

11 AM Registration/Paper/Pick-Up
Exhibitor Numbers

11:30 AM Poultry Check-In

12 PM Poultry Show

1 PM Beef/Sheep Weigh-In

3:30 PM Goat Show

• The Mater Showmanship Contest
will take place 30 minutes after the
conclusion of the 4-H Goat Show.

Monday, July 15th

9 AM Sheep Show

11 AM Beef and Dairy Steers

5:30 PM Swine Show

Tuesday, July 16th

• 4-H Dairy Show will begin at the
conclusion of the Open/Jr Beef Show
• Livestock released at the conclusion
of the Open/Jr Dairy Show. Auction
animals will be required to stay for the
auction.

6 PM Auction



Illinois Extension

UNIVERSITY OF ILLINOIS URBANA-CHAMPAIGN



Fayette County 4-H Events 2024

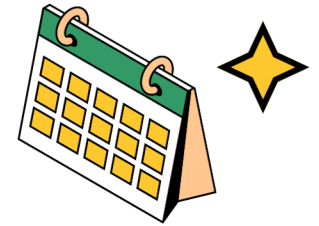

Date/Time	Event	Location
2/3 9-10 am	Beef Weigh-In	Fayette Co. Fairgrounds
3/23 9-10 am	YQCA Training	Fayette Co. Farm Bureau
3/23 10:30-11:30 am	New Member Workshop	Fayette Co. Farm Bureau
4/1 Midnight	Project Enrollment Deadline	4h.zsuite.org
4/2 5 pm	County Public Speaking Contest	U of I Extension Office, Vandalia
4/25 6-7 pm	YQCA Training	Fayette Co. Farm Bureau
4/27	State Public Speaking Contest	
5/1 Midnight	Swine, Dog, & Horse Ownership	To the office or by email.
5/4 9-10:30 am	Sheep & Goat Weigh-In	Fayette Co. Fairgrounds
6/3 Midnight	Fair Entry Deadline	fayette4-hfair.fairentry.com
6/15 9-11 am	Fayette Co. Fairgrounds Clean-up	Fayette Co. Fairgrounds
6/17 Midnight	State Fair Nominations	To the office or by email.
6/17 Midnight	Fayette Co. Stall Registrations	
7/1 Midnight	YQCA & QAEC Training Deadline	
7/11-16	Fayette Co. 4-H Fair	Fayette Co. Fairgrounds
8/10	Illinois 4-H State Fair General Project Judging	Springfield, IL

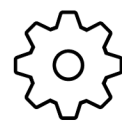
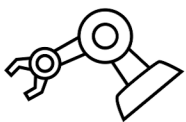



Fayette County Rules & General Information

Unit 21 County Rules and Information

1. **COMMUNITY CLUB MEMBER ELIGIBILITY:** Any boy or girl, regardless of race, creed, color, or handicap, who is 8-18 years of age on Sept. 1, 2023, may be a member of a 4-H community club. These members can hold offices, participate in the county 4-H project expo/fair/interview, and participate in the 4-H awards program. A list of available clubs in Fayette County can be provided by the office. Mentally challenged adults who are over the age of 18 may also be a 4-H member.
2. **SPECIAL INTEREST CLUB MEMBERS ELIGIBILITY:** Any boy or girl, regardless of race, creed, color, or handicap, who is 8-18 years of age by September 1, 2023, may be a member of a 4-H SPIN (Special Interest) Club. 4-H'ers enrolled in SPIN Clubs is eligible for full membership, awards, scholarships, and exhibit opportunities.
3. **INDEPENDENT MEMBER ELIGIBILITY:** 4-H'ers do not have to enroll in a community club to participate fully in the 4-H program. Members who cannot or do not wish to enroll in a club may enroll as "Independent Members." Independent members must meet with an adult mentor (non-related) at least four times during the year to be eligible to exhibit at the 4-H show. Independent members may apply for all awards. Members wishing independent status must request an application form and return it prior to January 1, 2024. Independent members are allowed to exhibit at the 4-H show and may sell animals in the auction as long as they have met at least four times with their mentor.
4. **4-H CLOVERBUD MEMBER ELIGIBILITY:** Youth ages 5-7 years of age by September 1, 2023, may enroll in 4-H as 4-H Cloverbuds. Cloverbuds may learn about 4-H by attending club meetings, taking 4-H projects and participating in 4-H shows and events. Cloverbuds do not hold club offices. Cloverbud members are not allowed to exhibit livestock or horses. Cloverbud members do not receive premiums but are allowed to exhibit at the 4-H show and receive a ribbon. Members enroll in the "Cloverbud" project but may order manuals especially suited for youth ages 5-7 listed on the project selection sheet.
5. **PROGRAM FEES:** All members, regardless of classification must pay the \$20 Illinois State Program Fee. The fee helps support state programs and events, as well as provides funds for local events, workshops, recognition, office materials, manuals and leadership training opportunities. Members who belong to more than one club are only required to pay the fee one time. The fee covers 12 months of 4-H club membership. The date of the renewal is September 1 for community club, SPIN club, and independent and Cloverbud members.
***County Program fees are covered by Southwestern Electric Coop.**
6. **MULTI-COUNTY MEMBERSHIP:** Members may join more than one 4-H club in two different counties. They are only required to pay **one** program fee. They only receive premium funds in the county where their membership fee was paid.
7. **ENROLLMENT YEAR:** The 4-H year runs from September 1 through August 31 of the current year. "4-H age" is determined as the age of the 4-H member was on September 1, 2023.
8. **ACCESSIBILITY:** Anyone needing reasonable accommodation to participate in a 4-H program should contact the Fayette County Extension Office.

Unit 21 4-H Policies

1. **INDIVIDUAL CODE OF CONDUCT:** All 4-H members & adults must abide by the 4-H Code of Conduct at all 4-H events and during club meetings. The code is found on the following page.
2. **CLUB POLICIES:** All 4-H Clubs must submit a secretary's report and an audited treasurer's report annually. Additional rules regarding club operations and finance are outlined in the Illinois 4-H Policies Manual. Clubs which do not comply will not be allowed to re-enroll the following year.
3. **COUNTY POLICIES:** Changes in these 4-H rules are made by Extension Staff with the guidance of the 4-H Leadership Council and Livestock Committee.
4. **STATE POLICIES:** The Fayette County 4-H Program must adhere to all the rules, regulations, and policies of the State 4-H program as outlined in the Illinois 4-H Policies manual. Anyone may request a copy of the policy manual from the county office.
5. **FEDERAL TRADEMARK REGULATIONS:** The 4-H Clover is protected by trademark laws. Specific rules must be followed when using the 4-H clover. Anyone may request a copy of those rules from the county office.
6. **GRIEVANCE PROCEDURES:**
 - a. Members of the public, who are involved in Fayette County Extension Programs, have the right to bring complaints to the attention of the County Director with assurance that the complaints will receive a review and be accorded fair and equitable treatment. The County Director can be reached at 618-283-2753.
 - b. A *formal written complaint* may be made to the County Director. A review team consisting of the County Director, Youth Educator, and other Extension staff will be involved in reviewing the situation. The County Director will initiate discussion, considerations, and resolution within 20 working days from the date of the complaint.
 - c. If the grievant is not satisfied with the informal/formal process at the Unit level, the grievant may present a formal written grievance to the Regional Director.
7. **SHARED MEMBERSHIP:** Illinois 4-H members may participate in 4-H under a shared membership arrangement with another county; however, approval must be granted by both counties prior to enrollment by completing the *4-H Shared Membership Agreement* form. Members may not benefit economically from exhibiting the same project at multiple local or county 4-H exhibitions, fairs, or shows, including premiums, auctions, trophies, ribbons, and other awards. Members may apply for 4-H awards or recognition in only one county. 4-H program fee should be paid in the county of residence. This policy is designed to meet the changing needs of today's families including youth who live with parents or guardians in dual or multiple legal residences due to divorce or separation. Shared membership is also an option when a project(s) or exhibitions are NOT OFFERED in the county of residence.
8. **TAX IMPLICATIONS FOR PRIZES, GIFTS OR AWARDS:** Program Participants (including minors) will be required to provide their Social Security Number or foreign national tax ID number prior to receiving a prize, gift, or award to ensure proper IRS reporting as required by law. This sensitive information is kept confidential and handled through security protected software (PEAR). Participants will not be eligible for a prize, gift, or award if social security or foreign national tax ID information is not provided.

Unit 21 4-H Member Code of Conduct

All participants of the Illinois 4-H program are responsible for their conduct to University of Illinois Extension personnel and/or volunteers of the 4-H program. All 4-H members are expected to maintain the following standards:

1. Be courteous and respect others.
2. Obey all the laws of the locality, state, and nation and University of Illinois and Extension policies and guidelines as well as 4-H Program Guidelines and those of the local club/group.
3. Treat all people fairly and animals humanely.
4. Respect the property of others.
5. Respect the authority of adult or youth volunteers, paid Extension Staff, and others in leadership roles.
6. Use appropriate language and wear acceptable clothing at 4-H activities and events.
7. Show kindness to others and give assistance when needed.
8. Be honest and honor commitments.
9. Strive for personal best and keep trying to improve.
10. Accept responsibility for personal choices.

Members and parents sign this agreement as part of their 4-H enrollment.

The following conduct will not be allowed by any youth participating in 4-H activities or events and is subject to disciplinary action, which could include being removed from the program and activity:

1. Possession, use, or distribution of alcohol and other controlled substances, including tobacco products.
2. Theft or destruction of public or private property.
3. Involvement in sexual misconduct or harassment.
4. Unauthorized possession or use of weapons or dangerous materials, including fireworks.
5. Fighting or other acts of violence.
6. Willfully breaking curfew.
7. Unauthorized use of vehicles.
8. Leaving the site of the event without permission.
9. Participating in gambling.
10. Absence from the planned program.
11. Intentionally interfering with or disrupting the event.
12. Use of profane, abusive, or sexually explicit language.
13. Public displays of affection or inappropriate actions.
14. Failure to comply with direction of Extension personnel, including designated volunteers.

4-H members' behavior is expected to demonstrate the character traits of trustworthiness, respect, responsibility, fairness, caring and citizenship.

Benefits of Membership

1. **4-H NEWSLETTER:** All 4-H families and volunteers will receive a 4-H newsletter detailing upcoming 4-H events and activities. These newsletters contain important information. You may request a paper copy or email copy of the newsletter when you enroll.
2. **ILLINOIS 4-H PROJECT GUIDE:** The 4-H Project Selection Guide lists all the projects available from the State 4-H office. It briefly describes these projects, gives suggested ages for each project level and lists available publications. Special 4-H awards and programs, which may be applied for, are also listed in the Pick Your Project Guide.
3. **4-H MANUALS:** 4-H members may order a project manual for each project that they enroll in, if available. **Members will receive one free book of their choice as long as they get their order in by the deadline set by the office.** 4-H Leaders and members are STRONGLY encouraged to recycle and reuse these 4-H manuals as much as possible to save money for families and the local office as well as encourage a “green” lifestyle. If you need more than one project manual families are to purchase their own at <https://shop4-h.org/collections/illinois-virtual-pop-up-shop>.
4. **DEMONSTRATIONS & TALKS:** 4-H members gain confidence by giving a talk or demonstration about at least one of their projects to their club each year.
5. **STATE 4-H EVENTS:**
 - a. **4-H MEMORIAL CAMP:** Youth ages 8-18 may attend summer camp at 4-H Memorial Camp in Monticello, IL. This is a great place to camp, make new friends, swim, learn lots of new things, sleep in log cabins, and have the best time!
 - b. **CITIZENSHIP WASHINGTON FOCUS:** Youth 15 and older by January 1 can attend a 7-day conference at the National 4-H Center in Chevy Chase, Maryland. While there, 4-H’ers will spend time in Washington, D.C. visiting the White House, Lincoln’s Memorial, Arlington Cemetery, Mt. Vernon, and many more historical sites. They will also meet congressional delegates. The trip is held every other year.
 - c. **STATE 4-H ILLINI ACADEMIES:** Youth 14 and older by January 1 can attend a state-wide conference. At this unique learning experience, 4-H’ers will meet with other 4-H’ers from around the state to study projects and various topics in a university setting, a good way to meet new friends and become familiar with the various places throughout Illinois. This program takes place every other year.
 - d. **STATE 4-H JR. LEADERSHIP CONFERENCE:** Youth in grades 7 & 8 may attend a statewide conference. At this unique learning experience, 4-H’ers will meet with other 4-H’ers from around the state to learn about being a leader in their 4-H club.
 - e. **JUDGING CONTESTS:** 4-H’ers have the opportunity to participate in a wide variety of judging events throughout the year.
6. **COUNTY 4-H EVENTS:**
 - a. **4-H ACHIEVEMENT NIGHT:** An annual awards program is held for 4-H members and leaders.
 - b. **WORKSHOPS/CLINICS:** There are several workshops/clinics offered to 4-H members and the public throughout the year.
 - c. **PUBLIC SPEAKING/DEMONSTRATION CONTEST:** A county Public Speaking Contest is held, and the top speakers are eligible to attend the Illinois State Competition.
 - d. **4-H COMMITTEES:** 4-H Committees meet throughout the year to plan activities for upcoming 4-H events, evaluate project rules, select fair judges, settle project conflicts,

and to encourage participation in their project area. Adults and youth are welcome to be on any or all the 4-H committees. Contact the office about being on a committee.

- e. **4-H FUNDRAISERS:** There are several fundraisers for both youth and adults to help with throughout the year.
- f. **4-H PROJECT INTERVIEWS & LIVESTOCK SHOWS:** 4-H members are rewarded for the work they have done on their 4-H projects during the annual 4-H Fair. The time schedule and exhibit requirements will be included when they are released from the state.

7. **COUNTY AWARDS**

Livestock Records

An outstanding livestock record will be selected for each species, beef, dairy, goat, horse, poultry, rabbit, sheep, and swine.

Club Officer Awards

An outstanding Secretary, Treasurer, and Historian will be selected based on their submission of the Secretary books, Treasurer books, and club scrapbooks.

Membership Year Awards:

No application required. Members will be recognized for years of membership, in increments of 1st year, 5th year, 10th year, and 11th year. All cloverbud members will also be recognized for their participation.

Alumni Award: <https://extension.illinois.edu/sites/default/files/fayetteawardalumni.pdf>

Friend of 4-H Award:

<https://extension.illinois.edu/sites/default/files/fayetteawardfriend.pdf>

8. **STATE LEVEL AWARDS:** <https://4h.extension.illinois.edu/participate/awards-scholarships>

- a. **My Illinois 4-H Experience:** Applicants, ages 8-18 years by the beginning of the 4-H year, must complete the application by marking the experiences achieved over the September 1, 2023 – August 31, 2024 program year. Members will be recognized based on the level achieved-bronze, silver, gold, diamond or emerald.
- b. **Illinois 4-H Award Application:** Applicants must be 15-18 years of age by September 1 of the 4-H program year in which they are applying. The application consists of a 3-page form and attached pages with responses to two required essay questions. **No additional lines may be added to sections or pages (besides those required for the essay questions) to this application.** The application must be submitted to the county office by TBD deadline.
- c. **Excel Level Recognition for Clubs:** Any club enrolled with their local Extension Office by August 1 of the calendar year in which they are submitting an application is eligible to apply. The application should reflect the involvement of club members and leaders working together as a team toward the accomplishment of a common goal. The activities and projects must relate to the specific award category and must be completed from September 1 of the previous year to August 31 of the year in which the application is being completed.

4-H Records

4-H teaches good record keeping skills to youth and adults. A permanent 4-H record helps members track their 4-H activities. In addition, several projects, listed below, require records to be submitted as part of their 4-H Fair exhibit:

Livestock Records: ALL 4-H members taking a livestock project are **REQUIRED** to complete a 4-H Livestock record for the following species: beef, dairy, swine, sheep, poultry, rabbit, meat & dairy goat, and horse. These records are to be turned in at the mandatory livestock meeting on weigh-in day at the fair with information complete up to the date of the fair. **(All 4-H members who are showing livestock MUST be in attendance for the MANDATORY Livestock Meeting.)** These records will be inspected by the Livestock Committee. The records must be completed and turned in with other end-of-the-year records:

1. **HORSE:** All 4-H Members taking a horse project are **REQUIRED** to complete the following forms:
 - a. A 4-H Horse Lease Form or Ownership form showing 2 pictures of your horse must be submitted to the Extension Office by May 1.
 - b. A 4-H Livestock record must be submitted at the county 4-H fair check-in to see that they have been started. Final records must be submitted to the office by the County Award deadline.
 - c. Proof of Coggins test put be submitted at the time of exhibition at the 4-H Fair.
2. **DOG/CAT:** All 4-H members taking a dog or cat project are **REQUIRED** to complete the following records:
 - a. A 4-H Dog Lease Form or Ownership form show 2 pictures of your pet must be submitted to the Extension office by May 1. 4-H Dog Ownership forms will be included in the back of the project handbook.
 - b. Proof of pet vaccination records and health certificates must be shown prior to the 4-H Fair. Dog and cat projects are required to have a Rabies and distemper vaccination. If these forms are not available, the animal will not be allowed to show.
3. **SWINE:** All 4-H members taking a swine project are **REQUIRED** to complete the following records:
 - a. Barrow and Gilt Ownership form showing 2 pictures of your barrow (one of each side) must be submitted to the Extension Office by May 1. Pictures must be attached to the appropriate ownership form to be accepted and assigned Fayette County 4-H Swine tag must be visible in 1 picture.
4. **SHEEP/GOAT:**
 - a. Weigh in at Fayette County fairgrounds. May 4, 2024
 - i. Sheep: Wethers
 - ii. Goats: Wethers
5. **Beef/Dairy Steers:**
 - a. Weigh in at Fayette County Fairgrounds. February 3, 2024

Forms are available in the office and online at: <https://extension.illinois.edu/cefi/4-h-fayette-county>

Fayette County 4-H Show Policies and Regulations

Entry Procedure and Deadlines

1. Enrollments and project selections are *requested* by January 1 for all returning members. 4-H'ers must be enrolled in each 4-H project they wish to exhibit at the 4-H Fair by **April 1**. 4-H'ers may not add any additional projects after April 1. 4-H'ers should check their enrollments with their leader or through 4h.zsuite.org prior to April 1 to ensure they are in the correct projects.
2. Members must attend **at least 4 club meetings, events, or activities** PRIOR TO JULY 1, 2024 to be eligible to participate in the 4-H fair, 4-H auction and public speaking contest.
3. **All entries must be made in Fair Entry**. Each enrolled 4-H member will receive instruction on how to complete this before the **June 1st deadline**. The University of Illinois Extension reserves the right to reject any entry not meeting these requirements.
4. **No additions to the entries will be allowed after June 1, unless special approval is granted by the Extension office. THIS IS WHY WE RECOMMEND ENTERING ANYTHING THAT COULD STILL BE AN OPTION FOR YOU TO BRING TO THE FAIR.**
5. Entry tags will be given to each 4-H family in advance of the fair by request. Project entry tags will be available at check-in prior to each show. 4-H'ers should firmly attach the tag to their exhibit. If there are separate pieces to your project, please label each piece so nothing is lost. Please note: no tags are needed for animal projects.
6. 4-Hers are not allowed to change their exhibit tag in any way. If you did not receive a tag that you thought you should receive, contact an Extension staff member immediately. If you did not receive a tag, that means you are not enrolled in the project or did not mark it as an exhibit when you enrolled. You may not add projects after April 1, so you will not be allowed to bring a project unless you received a tag for it.
7. 4-Hers will **not** be penalized for **not** bringing an exhibit they originally signed up for.
8. Cloverbud 4-H members may show projects/displays as a group or individual that they created during the past 4-H year. These entries will be judged during the general project show but will not receive premium money. Cloverbud members cannot show livestock.
9. Additional rules for exhibiting livestock, poultry, rabbits, and horses apply and may be found in the back of this handbook. Members are encouraged to read those directions completely.

Show Day Procedure & Project Exhibit Requirements

Before the Show

1. **EXHIBIT RULES:** Specific rules for each project are listed in this Show Book. In most cases, the exhibit listed is one of several activities taken from your project manual. Be certain to follow the rules listed in **this book EXACTLY**, even if they differ from your project manual. 4-H Show exhibits which do not meet these guidebook rules will not be eligible to receive an A rating.
2. **WORK OF THE EXHIBITOR:** Projects are to be constructed by the exhibitor, and they must have been made in the current 4-H year. The same product or speech that is selected at the county level must be exhibited at the State Fair, adjusted to State Fair class requirements.
3. **NUMBER OF ENTRIES:** Some projects allow you to bring more than one exhibit per project; others allow only one. Remember to select just one choice unless the project rules specifically say you can prepare more than one. In the visual arts project, you may enter a separate exhibit in any or all of the visual arts sub-divisions, but you may only bring one exhibit per sub-division. For example, you may enter chalk drawing in the “chalk, pigment and carbon” division and enter a quilt in the “heritage arts” division. Members are limited to one entry per show CLASS listed.
4. **CATEGORY:** In the rare cases where a project may have been entered in the wrong category, the superintendents, with approval from Extension staff, have authority to move a project to the correct class if it doesn't meet the requirements of the class it was originally entered in.

The Day of the Show

1. **ATTENDANCE:** 4-H members are encouraged to exhibit their own projects at the 4-H shows. Members unable to exhibit or who have a conflict **MUST** contact the Extension Office, their club leader, or the appropriate superintendent at least 48 hours in advance of the show. **The exhibitor is to make arrangements for another Fayette County 4-H'er** to exhibit his/her project. If the exhibitor is unable to exhibit his/her project, and does not contact the proper individuals, the project may not be shown. **Parents and Leaders may not exhibit a 4-H'er's project.**
2. **CONFERENCE JUDGING:** At the county 4-H shows, a judge will evaluate the quality and appearance of each exhibit. In addition, the judge will ask the 4-H member some questions about their project to assure their knowledge of the project. Parents are not allowed to assist the 4-H member at any time during the conference judging. Only the superintendents and junior superintendents will be allowed in the judging areas along with the 4-Her being judged. 4-Hers should dress nicely and be well groomed.
3. **SCORESHEETS:** Exhibits will be scored by the state score sheet for that project. A copy of score sheets are available online at: <https://4h.extension.illinois.edu/members/projects>
4. **PREMIUMS:** Monetary awards (4-H premiums) are given to 4-H members for completed projects based on project ratings at county 4-H shows. The amount varies each year based on the amount provided to the Illinois Department of Agriculture for the 4-H premium fund. These funds are appropriated by the State Of Illinois General Assembly. **Disclaimer:** *Premiums will be provided based on funds available. The Department of Agriculture shall use its best efforts to secure sufficient*

appropriations to fund premiums. In any year for which the General Assembly of the State of Illinois fails to make an appropriation sufficient to pay such, premiums may be curtailed.

- Members who do not exhibit at the County Show can show the project at a local club tour or achievement meeting to receive credit for exhibiting but will not receive premium money for the exhibit.
- Non-state projects are not allowed, by law, to receive a state premium.
- X Factor: A-5, B-4, C-3

5. **RIBBONS:** Projects will be scored against a score sheet which is available to anyone upon request from the county office.

- Based on that score, each exhibit will receive either a **blue, red or white ribbon**. Projects earning a blue ribbon “met the standards” in most categories of the score sheet. Projects “needing some improvement” will receive a red ribbon, and projects “needing much improvement” will receive a white ribbon.

6. **ILLINOIS STATE FAIR:** 4-H members who were 8 years of age by Sept. 1, 2023 may be selected to participate in the State Fair. Information about the state fair will be distributed at the 4-H Fair. Those participants chosen to participate in State Fair exhibits will be required to comply with all State Fair rules.

- Members must have been 8 years of age by Sept. 1, 2023 to exhibit at the Illinois State Fair in 2024.
- Members may exhibit one project only at the State Fair. If a member was selected in more than one area in either group, they must choose one and notify the county office by the date required of the county office.
- Members are responsible for transporting their project to the state fair and must be present to attend conference judging with their project on the specified days at the Illinois State Fair.
- Judging of State Fair General 4-H Exhibits for Fayette County will be held on **Saturday, August 10th, 2024**. The premium for each state fair exhibit is unknown at this time and depends on state funding.

7. **DURATION:** Exhibits must remain at the exhibit location throughout the length of the Show. No project may be removed (except live animals) until it is released by the Extension Staff. Members are responsible for picking up their items from the 4-H Show. The Extension Office does not accept responsibility for any projects left after the release time.

8. **NOT RESPONSIBLE:** Care will be exercised to prevent accidents or damage of any kind to the projects, but the superintendents and the Extension Staff will not assume any liability for damage to property or person.



2024 FAYETTE COUNTY 4-H GENERAL PROJECTS SHOW

*Thursday, July 11th at the Fayette County Fairgrounds
Under the Pavilion*

CLUB CHECK-IN TIMES WILL BE AS FOLLOWS:

- Club assigned times are on a yearly rotating basis.

<u>Check In Time</u>	<u>Clubs</u>
12:30 Check-In 1 PM Judging Start	St. James Hornets & Vandalia Wild Dogs
1:30 PM Check-In	Shafter Friends & Loudon Bunch
2:00 PM Check-In	Ramsey S&S, Golden Harvestors & Future Fayette Farmers
2:30 PM Check-In	Caprine Kids & Sefton Clovers

If an exhibitor is unable to make it to their designated club time, arraignments need to be made prior to the Fayette County 4-H General Project Show by calling the Fayette County Extension office. Exhibitors will then be assigned a new judging time accordingly.

Projects shall be placed on display after conference judging in the general projects building located next to the rabbit/poultry barn. Judges will make final decisions on Best of Show and State Fair Delegates on exhibits at the conclusion of the day's conference judging. Winners will be announced at the awards presentation. General Projects will be released at the conclusion of the awards presentation. The 4-H General Project Awards presentation is scheduled for **Friday, July 12th at 5:30 PM.**

State Fair Nominations and Alternates will be decided at the discretion of the Conference Judge in that area. Members may only show one project at the Illinois State Fair for General Projects and Food & Clothing, IF a member gets chosen in one or more areas to go to State Fair, that member must select one project. State Fair Nominees will need to submit their Nomination Form on declaration of going or not going to the Fayette County Extension Office no later than **Friday, July 16th**. Alternates will be notified if opening occurs and must notify the Extension Office of acceptance by **Monday, July 22nd**.

Exhibitors electing to go to the Illinois State Fair General Projects Show for Fayette County will have the opportunity to purchase discounted admission tickets through the Fayette County Extension Office. The 2024 Illinois State Fair General Projects Day for Fayette County will be **Saturday, August 10th, 2024.**

GENERAL PROJECT REGULATIONS

1. All exhibitors must comply with the 2024 Fayette County 4-H Club Show regulations.
2. Displays must sit inside a maximum **2' wide x 15" deep space** with a maximum height of **36"**. If made of poster board, it must be supported by sturdy backing (corrugated box, plywood, Styrofoam, etc.). Keep exhibit space requirements to a minimum. **Display may be something other than display board.** See #6 below.

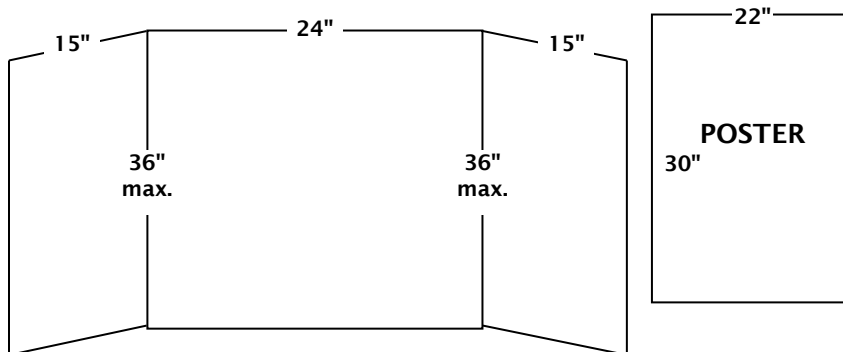

3. **MAKE ALL POSTERS WITH CARDBOARD VERTICAL**, using a maximum size of 22"x30".
4. Put Name and Club on all posters in front lower left-hand corner.
5. For entries requiring displays or posters, use charts, sketches, drawings, photographs, mechanical devices, models, etc. to demonstrate work done in project area.
6. Exhibits may include, but are not limited to, original works, objects, demonstrations, digital presentations, programs, websites, games, apps, performances, or posters which you have made. Choose whatever method best shows what you've learned. You must furnish any equipment you need for your exhibit. Internet service will not be provided for the exhibit. All exhibits must include something visual, such as a printed copy of a digital presentation, which will remain on display during the exhibition. Electronic equipment will only be used during your personal judging time and will not remain on display during the entire exhibit period.
7. **Handmade items must include written information explaining how the project was made and its intended use.**
8. To ensure that all your paperwork stays together with your project; it is recommended that any patterns or extra papers, such as recipes, be placed in a clear sheet protector. This is an optional request, but it may help keep loose papers organized. The use of sheet protectors is recommended for all binder exhibits. Binder exhibits will NOT be labeled "Do Not Touch".
9. **INNOVATION CLASSES** are open to any 4-H member enrolled in that project area. Members choosing to exhibit in the Innovation class may be enrolled in any level of the project they are studying. Members choosing to exhibit in the Innovation class decide the best way to show off their project mastery and knowledge for the year in that project category. Your exhibit should not fit in other exhibit options for this project. Some suggestions are provided for each category, but members may choose any method they want for demonstrating project learning as long as it does not fit in any other class in that category. Only selected projects categories have an Innovation option.
10. **READY4LIFE CLASSES** (Career & Entrepreneurship Exploration) are open to any 4-H member who was at least 11 by September 1 of that 4-H year. Members choosing to exhibit in the Ready 4 Life class may be enrolled in any level of the project they are studying. Exhibits should show the connection between the project area and related career or business opportunities. Members may choose any method they want for demonstrating project learning.
11. Projects should be brought to the judging and the 4-H member should stay with the project for a conference with the judge. During the conference, the member should be able to describe his or her project and explain how it was completed. The 4-H member should be the only one involved in the conference judging. **NO PARENTS WILL BE ALLOWED TO SIT WITH THEIR CHILD WHILE HE/SHE IS BEING JUDGED.**
12. The University of Illinois Extension staff and/or volunteers assume no liability for loss or damage to exhibits. All possible caution will be taken to protect the exhibit.
13. Any changes or errors in the rules and regulations will be posted online and will be the **FINAL AUTHORITY**. Therefore, any errors in this program book will not excuse failure to comply with current rules and regulations.

Project Exhibit Table of Contents



Aerospace -----	pg. 16	Health -----	pg. 36
Animal Science -----	pg. 16	Horse & Pony -----	pg. 80-81
Beef -----	pg. 72-74	Horticulture: Floriculture -----	pg. 36-37
Cat -----	pg. 75	Horticulture: Vegetable -----	pg. 37-39
Child Development -----	pg. 17	Intercultural/Passport to the World -	pg. 40
Civic Engagement -----	pg. 17-18	Interior Design -----	pg. 41
Clothing & Textiles -----	pg. 18-21	Leadership -----	pg. 41-43
Cloverbud -----	pg. 63	Maker -----	pg. 43
College & Career Readiness -----	pg. 21	Natural Resources -----	pg. 43-45
Communications -----	pg. 22-23	Photography -----	pg. 45-47
Community Service -----	pg. 23-24	Plants & Soils -----	pg. 47
Computer Science -----	pg. 24-25	Poultry -----	pg. 82-83
Consumer Education -----	pg. 25	Rabbits -----	pg. 83-84
Creative Writing -----	pg. 26	Ready4Life -----	pg. 48
Crops -----	pg. 26-27	Robotics -----	pg. 48-49
Dairy -----	pg. 76	Sheep -----	pg. 85
Dog -----	pg. 77	Shooting Sports -----	pg. 50
Do Your Own Thing (COUNTY)---	pg. 27	Small Engines -----	pg. 51
Drone -----	pg. 27	Small Pets -----	pg. 51-52
Electricity -----	pg. 28	Swine -----	pg. 86-87
Entomology -----	pg. 28-29	Theatre Arts -----	pg. 52-53
Esports -----	pg. 30	Tractor -----	pg. 53
Exploratory -----	pg. 30	Vet Science -----	pg. 54
Family Heritage -----	pg. 30	Video/Filmmaking -----	pg. 54-55
Foods & Nutrition -----	pg. 31-34	Visual Arts -----	pg. 55-60
Forestry -----	pg. 34-35	Weather -----	pg. 60-61
Geology -----	pg. 35	Welding -----	pg. 61
Goat -----	pg. 78-79	Woodworking -----	pg. 61-62

AEROSPACE

Each county may send 2 entries total from 50130, 50131 50132.

Model Rocketry (SF 50130)

Open to youth in Aerospace 1, Aerospace 2, Aerospace 3, and Aerospace 4

Exhibit one model rocket assembled or made by the member. The exhibit will be a static display. The model rocket should be in good flying condition. DO NOT include the rocket engine with your exhibit. The rocket will not be launched. Attach the printed directions for construction of the rocket if any were used.

Aerospace Display (SF 50131)

Open to youth in Aerospace 1, Aerospace 2, Aerospace 3, and Aerospace 4

Prepare a display related to the aerospace project that does not fit in the model rocketry class. The exhibit may include, but isn't limited to, original works, objects, demonstrations, digital presentations, programs, websites, games, apps, performances, or posters that you have made. Choose whatever method best shows what you've learned. You must furnish any equipment you need for your exhibit. Internet service will not be provided for the exhibit. All exhibits must include something visual, such as a printed copy of a digital presentation, which will remain on display during the exhibition. Electronic equipment will only be used during your personal judging time and will not remain on display during the entire exhibit period.

Aerospace Ready4Life Challenge

For Ready4Life Career & Entrepreneurship Exploration exhibit opportunities for this project area, visit the Ready4Life section of this document.

ANIMAL SCIENCE

For youth enrolled in Beef, Cat, Dairy Cattle, Dog, Horse, Goat, Rabbits, Poultry, Sheep, Small Pets 1, Small Pets 2, Small Pets 3, Swine

Each county may submit 2 entries total from 50135A, 50135B.

Animal Science 1 (SF 50135A)

For youth enrolled in this project 1-2 years.

Prepare a display focusing on any activity related to an animal project. Demonstrate the skills and knowledge you have gained through the animal project you studied. The exhibit may include, but isn't limited to, original works, objects, demonstrations, digital presentations, programs, websites, games, apps, performances, or posters which you have made. Choose whatever method best shows what you've learned. You must furnish any equipment you need for your exhibit. Internet service will not be provided for the exhibit. All exhibits must include something visual, such as a printed copy of a digital presentation, which will remain on display during the exhibition. Electronic equipment will only be used during your personal judging time and will not remain on display during the entire exhibit period. Live animals are not permitted as exhibits in this area. For safety reasons, exhibits cannot include glass, syringes with needles, or any other sharp objects.

Animal Science 2 (SF 50135B)

For youth enrolled in this project 3 or more years.

Prepare a display focusing on any activity related to an animal project. Demonstrate the skills and knowledge you have gained through the animal project you studied. The exhibit may include, but isn't limited to, original works, objects, demonstrations, digital presentations, programs, websites, games, apps, performances, or posters which you have made. Choose whatever method best shows what you've learned. You must furnish any equipment you need for your exhibit. Internet service will not be provided for the exhibit. All exhibits must include something visual, such as a printed copy of a digital presentation, which will remain on display during the exhibition. Electronic equipment will only be used during your personal judging time and will not remain on display during the entire exhibit period. Live animals are not permitted as exhibits in this area. For safety reasons, exhibits cannot include glass, syringes with needles, or any other sharp objects.

Animal Science Ready4Life Challenge

For Ready4Life Career & Entrepreneurship Exploration exhibit opportunities for this project area, visit the Ready4Life section of this document.

BEEF

See Animal Science for non-livestock or LIVESTOCK section for LIVE animal shows.

CAT

See Animal Science for non-livestock or LIVESTOCK section for LIVE animal shows.

CHILD DEVELOPMENT

Each county may submit 3 entries from 50141.

Child Development (SF 50141)

Prepare a display that demonstrates the skills and knowledge you have gained studying child development. Topics might include, but are not limited to, selecting age-appropriate toys and activities, explaining child behavior, or recognizing child safety concerns. The exhibit may include, but isn't limited to, original works, objects, demonstrations, digital presentations, programs, websites, games, apps, performances, or posters which you have made. Choose whatever method best shows what you've learned. You must furnish any equipment you need for your exhibit. Internet service will not be provided for the exhibit. All exhibits must include something visual, such as a printed copy of a digital presentation, which will remain on display during the exhibition. Electronic equipment will only be used during your personal judging time and will not remain on display during the entire exhibit period. For safety reasons, exhibits cannot include glass, syringes with needles or any other sharp objects.

Child Development Ready4Life Challenge

For Ready4Life Career & Entrepreneurship Exploration exhibit opportunities for this project area, visit the Ready4Life section of this document.

CIVIC ENGAGEMENT

Each county may submit 2 entries total from classes 50145, 50146, 50147, 50148. **Due to space restrictions, exhibits are limited to 2' 6" wide and 15" deep.**

Civic Engagement 1 (SF 50145)

Exhibit a display illustrating one of the following options: 1) personal information about yourself – who you are, things you like to do, things you are good at, your favorites; 2) your feelings and how you handle these feelings; 3) your family, their responsibilities, how you work together. **Due to space restrictions, exhibits are limited to 2' 6" wide and 15" deep.**

Civic Engagement 2 (SF 50146)

Exhibit a display illustrating one of the following options: 1) your neighborhood; 2) how you were a good neighbor or led a service project for your community; **OR** 3) a Citizenship Challenge that you helped organize and lead (see the project book for details). **Due to space restrictions, exhibits are limited to 2' 6" wide and 15" deep.**

Civic Engagement 3 (SF 50147)

Exhibit a display illustrating one of the activities that you completed within your project as it relates to one of the following categories in the manual: 1) Government; 2) Business and Industry; 3) Transportation, Communication & Utilities; 4) Culture & Heritage; 5) Natural Resources & Environment; 6) Education; 7) Organizations within your community; 8) Tourism; **OR** 9) Support Systems within your community. **Due to space restrictions, exhibits are limited to 2' 6" wide and 15" deep.**

Civic Engagement Group Exhibit (SF 50148)

Open to clubs and groups whose members are enrolled in any Civic Engagement project

Exhibit a display illustrating how your group led a service project in your community. The exhibit may include, but isn't limited to, original works, objects, demonstrations, digital presentations, programs, websites, games, apps, performances, or posters which you have made. Choose whatever method best shows what you've learned. You must furnish any equipment you need for your exhibit. Internet service will not be provided for the exhibit. All exhibits must include something visual, such as a printed copy of a digital presentation, which will remain on display during the exhibition. Electronic equipment will only be used during your personal judging time and will not remain on display during the entire exhibit period. The display must be accompanied by 3 or more 4-H members at the time of the judge's critique. Club members should make a 5- to 10-minute presentation to the judge. All club members present for the judge's critique

should be able to discuss the project and answer questions. Only club members present for judging who participate in the actual critique and presentation are eligible for ribbons and premiums. Cloverbuds are not eligible for state fair and cannot be promoted and participate in a group presentation at state fair. Due to space limitations, exhibits are limited to 2'6" wide and 15" deep.

Civic Engagement Ready4Life Challenge

For Ready4Life Career & Entrepreneurship Exploration exhibit opportunities for this project area, visit the Ready4Life section of this document.

CLOTHING & TEXTILES

Each county may submit 3 clothing entries total from 50151a-c, 50152 a-c, 50153 a-c; 2 shopping entries from 50154, 50155, 50156

Clothing 1-3

All exhibits entered in Clothing 1-3 will be judged based on their construction and fit (if applicable). Exhibitors bringing garments should not wear their garments when they arrive for judging. The garment will be reviewed by the judges for construction first. Exhibitors will be asked to change into the garment as the second step of the judging process. If the garment was constructed for another individual, that individual must be present to wear the garment for the judge. (Only the exhibitor who made the garment is eligible for ribbon and premium.) Construction and appearance will both be considered during judging. If a pattern was used to make the item, the pattern instructions, either written or electronic, are to be included with the exhibit. Exhibit tags should be attached to the garment, not to the hanger.

Members wishing to exhibit knitted items should enroll in Visual Arts Fiber (if original) or Visual Arts Fiber Non-Original AGES 8-10 ONLY (if made from a pattern and youth is ages 8-10). Youth over age 10 who use a pattern should enroll in Visual Arts Heritage Arts. **We strongly encourage youth interested in pursuing quilting to enroll and exhibit in the Visual Arts Quilting project area.** Youth may still exhibit quilts in any level of Clothing as a "Sewn Non-Clothing" item, but these quilts will be judged using the Clothing rubric that evaluates the sewing skills and construction of the item. If exhibiting quilts in the Clothing area, all work on the quilt MUST be completed by the 4-H member. You cannot exhibit a quilt that was quilted by someone else. Quilts can be hand OR machine quilted as long as ALL work is completed by the exhibitor.

CLOTHING

Clothing 1 – FUNdamentals (SF 50151a, 50151b, 50151c)

Exhibit one of the following in either the Non-Sewn, Sewn Non-Clothing, or Sewn Clothing exhibit divisions:

Non-Sewn Exhibits (SF 50151a) Exhibit one of the following:

- Clothing Portfolio – Complete at least three different samples/activities from Chapter 2 and/or Chapter 3 of the project manual. Examples of samples you might include: How Two Magically Become One, pages 85-86; No Fear of Fray, pages 93-95; Two Sides of the Moon, pages 97-99; On the Flip Side, pages 101-104; Basic Hand Sewing Skills, pages 106-108. The Portfolio should be placed in an 8 ½" x 11", 3 ring binder. Include an appropriate cover, dividers, and table of contents. NOTE – additional pages can be added each year but must be dated with the year. See pages 9-10 of the project manual for portfolio formatting.
- Fabric Textile Scrapbook – Must include at least 5 different textile samples. Use Textile Information Cards template on page 41 in the project manual to identify fabric swatches. Completed textile cards should be placed in an 8 ½" x 11", 3-ring binder. Include an appropriate cover. See project manual, pages 42-74, for fabric options and fabric science experiments.
- What's the Difference - What's the Price Point – Exhibit may include a notebook, poster, small display sharing a project comparison and price point. See activity, pages 118-120. Exhibit should include PHOTOS; NO actual PILLOWS.

Sewn Non-Clothing Exhibits (SF 50151b) Exhibit one of the following:

- Pillowcase
- Simple Pillow – no larger than 18" x 18"
- Bag/Purse – no zippers or button holes

- Other non-clothing item using skills learned in project manual

Sewn Clothing Exhibits (SF 50151c) Exhibit one of the following:

- Simple top
- Simple pants, shorts, or skirt – no zipper or button holes
- Simple Dress – no zipper or button holes
- Other – other wearable item using skills learned in project manual (apron, vest, etc.)

Beginning Sewing Exhibits – exhibits in **Clothing 1** must be made from medium weight woven fabrics that will sew and press smoothly, flannel/fleece is acceptable. Solid color fabrics or those having an overall print are acceptable. We strongly advise youth do not select fabrics with plaid or stripe patterns as judges will expect stripes to match at seams, which is a more advanced-level skill. NO NAPPED or JERSEY KNIT fabric. Patterns should be simple WITHOUT DARTS, SET-IN SLEEVES, and COLLARS. Raglan and loose flowing sleeves are acceptable.

Clothing 2 – Simply Sewing (SF 50152a, 50152b, 50152c)

Exhibit one of the following in either the Non-Sewn, Sewn Non-Clothing, or Sewn Clothing exhibit divisions:

Non-Sewn Exhibits (SF 50152a) Exhibit one of the following:

- Clothing Portfolio – Complete at least four different samples/activities from Chapters 2, 3 AND/OR 4 of the project manual. The Portfolio should be placed in an 8 ½" x 11", 3 ring binder. Include an appropriate cover, dividers, and table of contents. NOTE – this can be a continuation of a Portfolio created in Clothing 1. Additional pages can be added each year but must be dated with the year created. See project manual, pages 9-11, for portfolio formatting.
- Expanded Textile Science Scrapbook – Must include at least 10 different textile samples. Use Textile Information Cards template on page 39 in the project manual to identify fabric swatches. Completed textile cards should be placed in an 8 ½" x 11", 3 ring binder. Include an appropriate cover. See project manual, pages 40-82, for fabric science experiments.
- Design Basics – Understanding Design Principles – Exhibit should include a learning experience that demonstrates the design principles and elements involved when selecting fabric for clothing and accessories. See project manual, pages 17-20, for design suggestions.
- Entrepreneurial Sewing – Exhibit should highlight items you made for sale online. Create an exhibit that displays products you made and posted online. Refer to the project manual, pages 161-167, for information on how to analyze the cost of similar purchased items to determine pricing of your products. The exhibit may be a notebook, poster or small display.

Sewn Non-Clothing Exhibits (SF 50152b) Exhibit one of the following:

- Recycled Clothing Accessory – Create a clothing accessory made from a used item. The item must be changed in some way in the redesign process. The finished accessory must reflect at least one skill learned in the project and exhibitor should be able to identify the skill used. A before picture and a description of the redesign process must accompany the exhibit. Clothing accessory may include: hat, bag, scarf, belt, etc.
- Non-Clothing Item OR Clothing Accessory – Create a non-clothing item or clothing accessory using at least one skill learned in this project. Exhibitor should be able to identify the skill used.

Sewn Clothing Exhibits (SF 50152c) Exhibit one of the following:

- Recycled Clothing – Create a garment from used textile-based items. The original used item must be redesigned (not just embellished or decorated) in some way to create a new wearable piece of clothing. The finished garment must reflect at least one skill learned in this project and exhibitor should be able to identify the skill used. A before picture and a description of the redesign process must accompany the exhibit.
- Constructed garment – Any garment with facings or curves. Should use at least one skill learned in this project and exhibitor should be able to identify the skills used. Garment should be appropriate for the age and experience of the member.

Clothing 3 – A Stitch Further (SF 50153a, 50153b, 50153c)

Exhibit one of the following in either the Non-Sewn, Sewn Non-Clothing, or Sewn Clothing exhibit divisions:

Non-Sewn Exhibits (SF 50153a) Exhibit one of the following:

- Clothing Portfolio – Complete at least four different samples/activities from Chapters 2, 3 AND/OR 4 of the project manual. The Portfolio should be placed in an 8 ½” x 11”, 3 ring binder. Include an appropriate cover, dividers, and table of contents. NOTE – this can be a continuation of a Portfolio created in Clothing 1 and/or Clothing 2. Additional pages can be added each year but must be dated with the year created. See project manual, pages 11-13, for portfolio formatting.
- Expanded Textile Science Scrapbook – Must include at least 10 different textile samples. Use Textile Information Cards template on page 29 in the project manual to identify fabric swatches. Completed textile cards should be placed in an 8 ½” x 11”, 3 ring binder. Include an appropriate cover. See project manual, pages 39-52, for fabric science experiments.
- Advanced Entrepreneurial Sewing – Using knowledge gained in project manual, Chapter 5, display one sample product with a business plan that includes a business ID and logo. The exhibit may be a notebook, poster or small display.

Sewn Non-Clothing Exhibit (SF 50153b) Exhibit one of the following:

- Recycled Clothing Accessory – Create a clothing accessory made from a used item. The item must be changed in some way in the redesign process. The finished accessory must reflect at least one skill learned in the project and exhibitor should be able to identify the skill used. A before picture and a description of the redesign process must accompany the exhibit.
- Non-Clothing Item OR Clothing Accessory – Create a non-clothing item or clothing accessory using at least one skill learned in this project. Exhibitor should be able to identify the skill used.

Sewn Clothing Exhibit (SF 50153c) Exhibit one of the following:

- Recycled Clothing – Create a garment from used textile-based items. The original used item must be redesigned (not just embellished or decorated) in some way to create a new wearable piece of clothing. The finished garment must reflect at least one skill learned in this project and exhibitor should be able to identify the skill used. A before picture and a description of the redesign process must accompany the exhibit.
- Constructed garment – Any garment constructed by the member which is appropriate for the age and experience of the exhibitor. Should use at least one skill learned in this project and exhibitor should be able to identify the skills used. Possible examples are wool garment, dress or jacket with set in sleeves and zipper or buttons and button holes, suit, evening gown or sport outfit.

Shopping in Style (SF 50154, 50155, 50156)

Members are encouraged to spend more than one year involved in this project, so they have time to learn what clothing styles look best on them while they also gain skills in building a versatile wardrobe and staying within their budget. Each year enrolled in Shopping should build on previous year’s learning experience. For all levels of this project, participants should bring a garment to display and model for the judge.

Exhibit one of the following options that align with the Shopping in Style level:

Shopping in Style: Beginning (Levels 1 & 2) (SF 50154) Choose **one** of the following activities from Unit 1 or Unit 2 of the project book to exhibit:

- Exhibit should consist of a garment that reflects your personal style along with a poster or report that 1) explains how this garment reflects your style and how it influences what others think of you; **OR** 2) how your personal style either aligns or contradicts what is considered to be “in style” today. **OR**
- Exhibit should include a garment you purchased along with a poster or report that explains or illustrates how this garment is either 1) a modern version of a fad or fashion from an earlier decade; **OR** 2) how this garment reflects a different ethnic or cultural influence. Exhibit should include garment you purchased along with a poster or report that provides 1) a body shape discussion and how body shape influences clothing selections; **OR** 2) a color discussion that provides an overview of how different colors complement different hair colors and skin tones and how that influenced garment selection. Poster or report may include pictures from magazines, the internet or actual photos of garments. **OR**
- Exhibit should include garment you purchased along with a poster or report that 1) explains how this garment uses the principles of design lines to create an illusion to alter appearance; **OR** 2) explains how color and texture of fabrics can complement or enhance appearance. Poster or report may include pictures from magazines, the internet, or actual photos of garments.

Shopping in Style: Intermediate (Levels 3 & 4) (SF 50155) Choose **one** of the following activities from Unit 3 or Unit 4 of the project book to exhibit:

- Exhibit should include two clothing items that were previously a part of your wardrobe that still fit but you don't wear anymore and pair them with something new to make them wearable again. Also include a report that explains why the garment was not being worn and what you did to transform it into a wearable garment again. **OR**
- Exhibit should include at least five pieces of clothing that exhibitor can mix and match to create multiple outfits. Include a poster or report that includes a clothing inventory AND describes what you have learned by completing this activity. Please bring at least one complete outfit from the selected clothing to display and model for the judge. **OR**
- Exhibit should include garment you purchased along with a poster or report that 1) includes a wardrobe inventory which indicates why you selected the garment you did, clothing budget, and cost of garment; **OR** 2) explains how advertising influences clothing purchases making a distinction between wants and needs; and how the purchase of this garment compliments and/or extends your wardrobe. **OR**
- Exhibit should include garment you purchased along with a poster or report that 1) describes a cost comparison of this item completed by the exhibitor when purchasing the garment; should include variety of shopping options and/or price tracking at stores over a period of time; **OR** 2) provides a quality comparison rating the specific clothing item purchased based on care, construction, cost and unique features; should include construction quality details, design features that influenced selection, cost per wearing, and garment care.

Shopping in Style: Advanced (Level 5 & 6) (SF 50156) Choose **one** of the following activities from Unit 5 or Unit 6 of the project book to exhibit:

- Exhibit should include garment you purchased along with a poster or report that summarizes care requirements not only for this garment but also for garments made of other natural and synthetic fibers; exhibit should also include a care cost analysis for garments of different fibers. **OR**
- Exhibit should include garment you purchased which you have repaired or altered along with a poster or report that provides a clothing inventory list which includes cost savings for repaired items as compared to purchasing replacement garments. **OR**
- Exhibit should include multiple garments you purchased along with a poster or report that provides plans and commentary for a fashion show that would capture the attention of an audience. Fashion show plans should identify target audience, include show venue, purpose of the show, and logistical plan for the fashion show. This should also include a financial plan. Exhibitor should be prepared to demonstrate modeling skills and bring at least one garment to display and wear.

Sewing & Textiles Ready4Life Challenge

For Ready4Life Career & Entrepreneurship Exploration exhibit opportunities for this project area, visit the Ready4Life section of this document.

COLLEGE & CAREER READINESS

Each county may submit 2 entries from 50365

Build Your Future (SF 50365)

Develop a career portfolio which includes the items listed below. Members are encouraged to spend more than one year involved in this project so they have time to thoroughly explore the learning modules and develop a greater understanding of planning and preparing for their future and develop a comprehensive career planning portfolio. The original OR photocopies of the completed activities from the project manual should be included in the portfolio. Each year enrolled in the project should build on the previous year's learning experiences.

- **First Year** – Complete a minimum of Activities 1-4 from the Build Your Future project manual which includes: Skills...Choices...Careers; Making Career Connections; Build Your Future Through Portfolios; and Education Pay\$.
- **Second Year** – Complete a minimum of Activities 5-7 from the Build Your Future project manual which includes: Career FUNds; Turn Your 4-H Passion Into Profit; and Pounding the Pavement.
- **Third Year** – Complete a minimum of Activities 8-9 from the Build Your Future project manual which includes: Putting the Pieces Together: Goals for the Future; and Pathways to Success.

COMMUNICATIONS

Each county may submit 2 entries total from 50368, 50369

Communications 1, 2, 3 (SF 50368)

For 1st year enrolled in project: Exhibit a binder portfolio showcasing at least three activities from the project manual. Show basic activities and anything that extended lessons. For 2nd and 3rd years in project: Include everything from earlier years' work and add a section showcasing at least four additional activities per year.

Journalism, News & Social Media (SF 50369)

Exhibit a binder portfolio showing the results of the appropriate year's activities noted below:

- **Year 1:** Accomplishments of a minimum of 5, 2-star activities, answering all the questions in the activities.
- **Year 2:** Results of doing a minimum of 5, 2-star activities, answering all the questions in the activities.
- **Year 3:** Results of doing a minimum of 5, 3-star activities. One of the activities must include writing an advance story, a follow-up story, or a feature story.
- **Year 4:** Results of doing at least 2, 2-star activities and 3, 3-star activities. If the activities include making an audio or videotape, State Fair will provide a way for the judge to view or listen to it.

Follow the instructions below to submit your entry.

1. Members are strongly encouraged to upload their submission to the State Communications Box folder at least two days prior to the beginning of State Fair. Members need to include their name and county in the title of the file. Upload files to: <https://go.illinois.edu/StateFairSubmissions>.
2. Members are also required to bring hard copy of their project to drop off the morning that their county is exhibiting at the state fair.

Communications Ready4Life Challenge

For Ready4Life Career & Entrepreneurship Exploration exhibit opportunities for this project area, visit the Ready4Life section of this document.

COMMUNICATIONS: PUBLIC SPEAKING

Counties may **advance a total of 3 entries** from any category to the state contest.

Enrollment in the Public Presentations project is required to participate in this section. No live animals are allowed in speeches. Counties may advance a total of 3 entries from any category to the state contest. A 4-H member may advance in one individual category and one team category. **Participating Youth must be 8 years of age on or before September 1, 2023. Participating youth turning 14 years of age on or before September 1, 2023 must enroll as advanced. Deadline to advance youth to Public Speaking State Contest: April 5, 2024.**

Resources:

Youth Looking for resources to help prepare for this contest can reference the following:

- [Finding your Voice: Public Speaking made Easy](#) (Public Speaking)

Formal Speech

Self-written | Notes Allowed | No props | Individual | 4-5 minutes for beginners; 5-6 minutes for advanced

Formal Speech - Original Beginner Ages 8-13 (SF 50501A)

Formal Speech - Original Advanced Ages 14 & Up (SF 50501B)

Formal Speeches share the presenter's own unique view and are intended to motivate, persuade, or inform an audience and may include a call to action. Youth may deliver a speech on any topic they wish.

Illustrated Speech

Self-written | Notes Allowed | Illustrations Required | Individual | 4-5minutes for beginners; 5-6 minutes for advanced

Illustrated Speech - Beginner Ages 8-13 (SF 50503A)

Illustrated Speech - Advanced Ages 14 & Up (SF 50503B)

Illustrated Speeches may be used to inform, persuade, or motivate the audience while using a visual aid. Visual aids may be two dimensional, three-dimensional, or digital. Youth may include audience participation. Digital visual aids must be stored on a USB flash drive. Illustrated speeches may be:

- How-to demonstrations which show the audience how to do something.
- Object lessons which use objects as metaphors to share a message.
- Educational models where drawings or diagrams help explain a topic.

Original Works

Self-written | Notes Allowed | Props and Costumes Allowed | Individual or 2-Person Team | Youth must provide manuscripts to judge | 4-6 minutes

Original Works – Individual (SF 50504)

Original Works – Team (SF 50505)

Original works must be written entirely by the presenter. It may be presented as an individual or a two-person team entry. Manuscripts must be sent in advance to the contest. Presentations may be designed for TV, radio, or online media and must be presented live. The types of entries could include:

- Prose and Short Stories
- Poetry/Spoken Word
- Broadcast Media Program
- Theatrical
- Combined Program: Combine any number of the above elements along with other creative presentation forms

Oral Interpretation

Published Work | Props and Costumes Allowed | Individual or 2-Person Team | Youth must provide manuscripts to judge | 4-6 minutes

Oral Interpretation – Individual (SF 50506)

Oral Interpretation – Team (SF 50507)

Presentations in Oral Interpretation must be published works, and manuscripts or transcripts must be submitted prior to the event. They may be presented as an individual or a two-person team entry. The types of entries could include:

- Prose and Short Stories
- Poetry
- Theatrical Interpretation
- Published Speech Recitation: Excerpt from a spoken presentation delivered by a public figure, such as Winston Churchill, Dr. Martin Luther King, Jr., or Maya Angelou
- Combined Program: Combine any number of the above elements along with other creative presentation forms

COMMUNITY SERVICE

Each county may submit 2 entries total from classes 50150a, 50150b, 50149). **Due to space restrictions, exhibits are limited to 2' 6" wide and 15" deep.**

Service Learning 1 (SF 50150a)

Exhibit a binder portfolio to reflect what the exhibitor accomplished in the four steps of service learning. This should include researching the need of the community and steps taken to serve that need. If exhibitor has been enrolled in project for multiple years, the binder portfolio should include previous years' work. Use of page protectors is recommended. A display board may accompany the portfolio, exhibits are limited to 2'6" wide and 15" deep

Service Learning 2 (SF 50150b)

Exhibit a binder portfolio to reflect what the exhibitor accomplished in the four steps of service learning. This should include a walk-about to observe needs, assessment of needs and assets in your community, surveys/interviews conducted to identify needs and the solution. If exhibitor has been enrolled in project for multiple years (including Service Learning 1), the binder portfolio should include previous years' work. Use of page protectors is recommended. A display board may accompany the portfolio, exhibits are limited to 2'6" wide and 15" deep.

Service Learning Group Exhibit (SF 50149)

Open to clubs and groups whose members are enrolled in any SERVICE LEARNING project. Due to space limitations, exhibits are limited to 2'6" wide and 15" deep.

Club members should be enrolled in Service Learning – Agents of Change (Level 1) and/or Raise Your Voice (Level 2).

Register community project at <https://4h.extension.illinois.edu/participate/4-h-community-service>, additional resources located on site. Exhibit should be educational in nature and should inform others of steps taken to engage club members in 1) identifying a local need, conducting a local needs assessment to find a need that is already visible in the community; 2) determine types of activities club members can/want to do; 3) List all of the activities, projects, or needs identified to review with club members; 4) create a plan and timeline for completing the service project (including-project goals; tasks involved; time commitment; permission needed from community stakeholders; a budget, a source for securing those funds; insurance needs; equipment and supplies; publicity; potential partners if additional help is needed; a risk management plan; and a process for evaluating the project; 5) prepare for club members to engage in the service project which may include instruction on completing specific tasks and/or educating members on how the project will benefit the community; 6) complete the project; 7) documentation of service experience with photos, videos; or written reports; 8) once project is completed, reflect on success and/or challenges encountered during execution of the service project; consider what you might do differently in future service projects. Create a display which will educate the public regarding the impact of the service project for both the community and the club members. The display should be staffed by 3 or more club members at the time of judging. Club members should make a 5-10 minute presentation for the judge. Club members should create a display which showcases the service project and the steps needed to complete it. Only club members present for the judging and who participate in the critique and presentation are eligible for ribbons and premiums. Exhibit size should not exceed 2' x 16" WIDE AND 15" deep.

COMPUTER SCIENCE

Each county may submit 3 entries total from 50158, 50159, 50160, 50161, 50162.

Exhibitors may bring computer equipment for demonstration purposes. Computers will not be furnished. Internet connections are not available for use by exhibitors. Any member found to be using computer software in a manner that infringes on copyright laws will be disqualified.

Beginning Visual Programming (SF 50158)

Open to youth in Computer Science Visual Based Programming

Exhibit a simple program using Scratch (or other simple visual programming language). The program should include 8 different commands including looping and getting input from the keyboard and mouse. All exhibits must include something visual, such as a poster or printed copy of a digital presentation, which will remain on display during the exhibition. Electronic equipment will only be used during your personal judging time and will not remain on display during the entire exhibit period.

Intermediate Visual Programming (SF 50159)

Open to youth in Computer Science Visual Based Programming

Exhibit a program using Scratch (or other simple visual programming language) that you have downloaded from the internet and modified. Compare the two programs and demonstrate the changes you made to the original program; **OR** create an animated storybook using Scratch (or other simple graphical programming language). All exhibits must include something visual, such as a poster or printed copy of a digital presentation, which will remain on display during the exhibition. Electronic equipment will only be used during your personal judging time and will not remain on display during the entire exhibit period.

Advance Visual Programming (SF 50160)

Open to youth in Computer Science Visual Based Programming

Exhibit a video game you have created in Scratch (or other simple visual programming language). All exhibits must include something visual, such as a poster or printed copy of a digital presentation, which will remain on display during the exhibition. Electronic equipment will only be used during your personal judging time and will not remain on display during the entire exhibit period.

Website Design (SF 50161)

Open to youth in any Computer Science Project Area

Exhibit an original website that you have designed using a programming language such as HTML (cannot be made with website builder like Wix or Squarespace). Internet access will not be provided, so exhibitors must supply their own internet hot spot or the website must be hosted on the exhibitor's computer. All exhibits must include something visual, such as a poster or printed copy of a digital presentation, which will remain on display during the exhibition. Electronic equipment will only be used during your personal judging time and will not remain on display during the entire exhibit period.

Text Based/Open Source Computer Science (SF 50162)

Open to youth enrolled in any Computer Science or robotics project Demonstrate the skills and knowledge you have gained through the Computer Science project using a text based programming language (Python, Java, C, etc.). The exhibit may include, but isn't limited to, original works, objects, demonstrations, digital presentations, programs, websites, games, apps, performances, or posters which you have made. Choose whatever method best shows what you've learned. Your exhibit should not fit in the other exhibit options for this project. You must furnish any equipment you need for your exhibit. Internet service will not be provided for the exhibit. Exhibits in this class may also demonstrate successful application of open source (publicly available) computing software and/or hardware, such as Raspberry Pi and Linux, to accomplish a task. All exhibits must include something visual, such as a poster or printed copy of a digital presentation or programming flowchart, which will remain on display during the exhibition. Exhibits in this area will be judged on the computer science programming. Electronic equipment will only be used during your personal judging time and will not remain on display during the entire exhibit period. Exhibits in this class must be able to fit on no more than a 3' x 2' space (or ground footprint).

Computer Science Ready4Life Challenge

For Ready4Life Career & Entrepreneurship Exploration exhibit opportunities for this project area, visit the Ready4Life section of this document.

CONSUMER EDUCATION

Each county may submit 2 entries total from 50166, 50168, 50169.

Entrepreneurship: Be the E! (SF 50166)

Exhibit a binder portfolio or display that includes the results of at least two completed activities from each year the exhibitor has been enrolled in the project. Completed activities from previous years should be included.

My Financial Future 1 Beginner (SF 50168)

Develop a Financial Planning portfolio which includes the items listed below. This project can be completed all in one year; or a member may take several years to explore each of the activities and develop a more detailed financial plan. The original OR photocopies of the completed activities from the project manual should be included in the portfolio. Each year enrolled in the project should build on previous year's experiences.

- **First Year** – Complete a minimum of Activities 1-6 from the My Financial Future – Beginner project manual which includes: Who Needs This?; Let's get SMART; Bringing Home the Bacon; Managing Your Money Flow; My Money Personality; and Money Decisions.
- **Second Year and Beyond** – Complete a minimum of Activities 7-11 from the My Financial Future – Beginner project manual which includes: Banking your \$\$\$\$; Charging it Up; Check it Out; Better than a Piggy Bank!; and My Work; My Future.

My Financial Future 2 Advanced (SF 50169)

Building on your previous work in My Financial Future – Beginner project, continue adding to your Financial Planning portfolio which includes the items listed below. Members are encouraged to spend more than one year involved in this project so they have time to thoroughly explore the learning modules and develop a greater understanding of financial literacy, planning for their future, and develop a comprehensive career and financial planning portfolio. The original OR photocopies of the completed activities from the project manual should be included in the portfolio. Each year enrolled in the project should build on previous year's learning experiences.

- **First Year** – Complete a minimum of two activities from Module 1: Earning Income and Career Planning and Module 2: Organizing Your Flow.
- **Second Year** – Complete all activities not previously completed in Module 1: Earning Income and Career Planning and Module 2: Organizing Your Flow; **AND** a minimum of two of the activities from Module 3: Working with Banks and Credit Unions: Bank on It and Module 4: Making Your \$ Work 4 U.

- **Third Year and Beyond** – Complete all activities not previously completed in Module 3: Working with Banks and Credit Unions: Bank on It and Module 4: Making Your \$ Work 4 U; **AND** a minimum of two activities from Module 5: Credit and Consumer Breadcrumbs.

Consumer Ed Ready4Life Challenge

For Ready4Life Career & Entrepreneurship Exploration exhibit opportunities for this project area, visit the Ready4Life section of this document.

CREATIVE WRITING

Each county may submit 2 entries total from 50367, 50371

Creative Writing (SF 50367)

Submit one of the following. The entry is to be typewritten on 8 ½ x 11 paper and include exhibitor's name. Entries must be original and **written for the 4-H project**. Stories should be double-spaced.

- **Short Story** – A fiction piece comprised of three basic elements: a theme, a plot and characters. Submit one story, maximum length – 2,000 words.
- **Essay** – A short nonfiction composition in which a theme is developed, or an idea is expressed. Submit one essay, maximum length – 500 words.
- **Feature Story** – Nonfiction human-interest story judged on interest to readers, writing style, readability, and thoroughness of coverage. Submit one story, maximum length – 1,000 words.

State Level Creative Writing: If promoted to state, follow the instructions below to submit your entry by August 1 to the state 4-H office.

2. Members are strongly encouraged to upload their submission to the State Communications Box folder by August 1, prior to the beginning of State Fair. Members need to include their name and county in the title of the file. Upload files to: <https://go.illinois.edu/StateFairSubmissions>
3. Members are also required to bring a hard copy of their project to drop off the morning that their county is exhibiting at the state fair.

Poetry (SF 50371)

Submit one of the following. The entry is to be typewritten on 8 ½ x 11 paper and include exhibitor's name. Entries must be original and **written for the 4-H project**. Poems may be single-spaced. The entries should be submitted by August 1 to the state 4-H office.

- **Rhymed Poetry** – An interpretation of a subject in rhymed verse. Submit a collection of three poems.
- **Free Style Poetry** – An interpretation of a subject in unrhymed verse. Submit a collection of three poems.

CROPS

Each county may submit 3 entries total from 50170, 50171, 50172, 50173.

Soybeans (SF 50170)

Exhibit five fresh plants (include root system that is washed) that are representative of member's 4-H project field; **OR** exhibit an experimental or educational project related to one experience from your project. Include explanation of the project in a report for public understanding. Include the member's crop records with the exhibit, such as the 4-H crop record found online at 4-H.illinois.edu, an FFA crops record, or similar information.

Corn (SF 50171)

Exhibit two fresh plants of field corn (include root system that is washed) that are representative of member's 4-H project field; **OR** exhibit an experimental or educational project related to one experience from your project. Include explanation of the project in a report for public understanding. *Sweet corn should be exhibited in Vegetable Gardening unless being raised under commercial contract by the exhibitor.* Include the member's crop records with the exhibit, such as the 4-H crop record found online at 4-H.illinois.edu, an FFA crops record, or similar information.

Small Grains (SF 50172)

Exhibit one gallon of the current year's crop of oats, wheat, rye, or barley that is representative of the member's 4-H project field; **OR** exhibit an experimental or educational project related to one experience from your project. Include explanation of

the project in a report for public understanding. Include the member's crop records with the exhibit, such as the 4-H crop record found online at 4-H.illinois.edu, an FFA crops record, or similar information.

Crops Innovation Class (SF 50173)

Open to youth enrolled in any Crops project

Demonstrate the skills and knowledge you have gained through the Crops project. This could be related to, but not limited to crop production, crop utilization or topics of interest to the member related to agronomy. The exhibit may include, but isn't limited to, original works, objects, demonstrations, digital presentations, programs, websites, games, apps, performances, or posters which you have made. Choose whatever method best shows what you've learned. Your exhibit should not fit in the other exhibit options for this project. You must furnish any equipment you need for your exhibit. Internet service will not be provided for the exhibit. All exhibits must include something visual, such as a printed copy of a digital presentation, which will remain on display during the exhibition. Electronic equipment will only be used during your personal judging time and will not remain on display during the entire exhibit period.

Crops Ready4Life Challenge

For Ready4Life Career & Entrepreneurship Exploration exhibit opportunities for this project area, visit the Ready4Life section of this document.

DAIRY CATTLE

See Animal Science for non-livestock project or LIVESTOCK section for LIVE animal shows.

DOG

See Animal Science for non-livestock project or LIVESTOCK section for LIVE animal shows.

Do Your Own Thing (COUNTY ONLY)

(No premium and not eligible for State Fair Entry)

Prepare a display on any activity you enjoy which is not covered by a 4-H Project.

DRONES: UNMANNED AERIAL VEHICLES/SYSTEMS

Each county may submit 2 entries total from 50375, 50376.

Choose one of the following classes based on your interest and skill level.

Each exhibitor must complete the first 2 sections, and at least 3 Real World Missions in the Quads Away Curriculum and display a completed mission logbook.

UAV Display (SF 50375)

Prepare a display related to the Drones/UAV project on the topic of your choosing. The exhibit may include, but isn't limited to, original works, objects, demonstrations, digital presentations, programs, websites, games, apps, performances, or posters which you have made. Choose whatever method best shows what you've learned. You must furnish any equipment you need for your exhibit. Internet service will not be provided for the exhibit. All exhibits must include something visual, such as a printed copy of a digital presentation, which will remain on display during the exhibition. Electronic equipment will only be used during your personal judging time and will not remain on display during the entire exhibit period. Non-UAV/ Drone projects should not be entered in this class (see Aerospace Display).

UAV Unmanned Aerial Systems (SF 50376)

Exhibit one unmanned aerial vehicle and associated system assembled or made by the member. UAV or drone exhibits in this class must be either originally designed or built from a kit of reconfigurable parts and components. These displays are limited to multicopters (tri, quad, hex, and octocopters), as well as FPV airplanes and flying wings with wingspans up to 36". A detailed build log with pictures, as well as a mission logbook must be included. The UAV MUST have a flight controller and utilize a camera/video transmission system. The exhibit will be a static display. The drone should be in good flying condition with batteries fully charged, and all UAS components (including video system) ready to demonstrate. DO NOT display your UAV with the propellers on, but rather on the table to the side of your UAV. The drone will not be flown. Attach the printed directions/instructions of the UAV if any were used.

ELECTRICITY

Each county may submit 3 entries total from 50177, 50178, 50179, 50180.

Electricity 1 (SF 50177)

(May only be battery-powered projects using battery components and wiring). Exhibit a momentary switch, simple switch, basic circuit, electromagnet, galvanometer, **OR** an electric motor. All projects must include a report explaining how the project was constructed and the principles demonstrated. Projects using paper clips, cardboard, thumbtacks, and brads are not eligible for state fair exhibits in electricity. Members wishing to exhibit these types of projects should consider exhibiting in Junk Drawer Robotics 1 or 2.

Electricity 2 (SF 50178)

(May only be battery-powered projects using battery components and wiring). Exhibit a circuit board demonstrating parallel and series switches, including a circuit diagram; 3-way or 4-way switch circuit using DC/battery; **OR** a basic electrical device (examples: rocket launcher, burglar alarm, etc.). All projects must include a report explaining how the project was constructed and the principles demonstrated. Projects using paper clips, cardboard, thumbtacks, and brads are not eligible for state fair exhibits in electricity. Members wishing to exhibit these types of projects should consider exhibiting in Junk Drawer Robotics 1 or 2.

Electricity 3 (SF 50179)

Exhibit a 120V lighting fixture or other appliance that uses a switch; **OR** two electrical household circuits using 120V materials to comply with National Electrical Code, one with a simple on/off switch to control bulb, and one using 3-way switches to control light from two locations; **OR** other project which demonstrates principles in the Wired for Power book. All electricity projects must include a report, explaining how the project was constructed, and principles for its operation. Recommendations can be found on the website.

Electricity 4 (SF 50180)

Exhibit any electronic or solid-state appliance. Exhibitor must be able to explain how the project was constructed, how it is to be used and how it works. When a project is being constructed, general safety and workmanship should be considered. All Electricity 4 projects must include a report explaining how the project was constructed, and principles for its operation. Recommendations can be found on the website.

Electricity Ready4Life Challenge

For Ready4Life Career & Entrepreneurship Exploration exhibit opportunities for this project area, visit the Ready4Life section of this document.

ENTOMOLOGY GENERAL

Each county may submit 2 entries total from 50183, 50184, 50185, 50186.

Size and number of exhibit cases should relate appropriately to the number of insects being displayed for a specified class. Cases should be no deeper than 4". Exhibitors should note that Entomology exhibits may be placed UPRIGHT for display.

Entomology 1 (SF 50183)

Exhibit 15 or more species representing four or more orders. The collection must be accurately labeled. Exhibitors must also include the Entomology 1 project manual, *Teaming With Insects 1*, with at least one completed activity for each year enrolled. **Rules for pinning and labeling insects are available at the following site:**
<https://extension.entm.purdue.edu/401Book/default.php?page=home>

Entomology 2 (SF 50184)

Exhibit 30 or more species representing eight or more orders. Collection must be accurately labeled. Exhibitors must also include the Entomology 2 project manual, *Teaming With Insects 2*, with at least one completed activity for each year enrolled. **Rules for pinning and labeling insects are available at the following site:**
<https://extension.entm.purdue.edu/401Book/default.php?page=home>

Entomology 3 (SF 50185)

Exhibit 60 or more species representing twelve or more orders. Collection must be accurately labeled. Exhibitors must also include the Entomology 3 project manual, *Teaming With Insects 3*, with at least one completed activity for each year enrolled. Rules for pinning and labeling insects are available at the following site: <https://extension.entm.purdue.edu/401Book/default.php?page=home>

Entomology Display (SF 50186)

Open to youth enrolled in Entomology 1, Entomology 2 or Entomology 3

Exhibit any activity or display related to Entomology that does not fit into Entomology Classes 1, 2 or 3 above. The exhibit may include, but isn't limited to, original works, objects, demonstrations, digital presentations, programs, websites, games, apps, performances, or posters which you have made. Choose whatever method best shows what you've learned. You must furnish any equipment you need for your exhibit. Internet service will not be provided for the exhibit. All exhibits must include something visual, such as a printed copy of a digital presentation, which will remain on display during the exhibition. Electronic equipment will only be used during your personal judging time and will not remain on display during the entire exhibit period.

Entomology Ready4Life Challenge

For Ready4Life Career & Entrepreneurship Exploration exhibit opportunities for this project area, visit the Ready4Life section of this document.

ENTOMOLOGY BEEKEEPING

Each county may send 2 entries total from classes 50188, 50189, 50190.

Create an exhibit that shows the public what you learned in the beekeeping project this year. **Note:** No beehives may be exhibited. Honey moisture content will be measured. Fill level: the honey should be filled to the jar shoulder, not over, nor under. Chunk honey should go in a wide-mouth jar, preferably one specially made for chunk honey (see beekeeping catalogs). Be careful to distinguish "chunk honey" (comb in jar) from "cut comb" (comb only in plastic box). *Honey exhibited (including chunk, cut comb, and sections) must be collected since the previous year's fair.*

Beekeeping 1 (SF 50188)

Exhibit an educational display for one (1) of the following:

- Flowers used to make honey. Display pressed flowers from ten (10) different Illinois plants that bees use for making honey.
- Uses of honey and beeswax.
- Setting up a beehive.
- Safe handling of bees.
- Equipment needed by a beekeeper.

Beekeeping 2 (SF 50189)

Exhibit one (1) of the following:

- Extracted honey: Three (3) 1# jars (glass, screw-top), holding 1# of honey each.
- Chunk honey (comb in jar): Three (3) 1# jars (wide-mouth, glass).
- Cut-comb honey: Three (3) 1# boxes (boxes are usually 4 ½" x 4 ½" in size).
- Section honey: Three (3) sections of comb honey (in basswood boxes or Ross rounds).
- Working with honey bees. Present a topic from your manual to teach fairgoers about working with honey bees. Use your knowledge and creativity to display this information on a poster or in a notebook.

Beekeeping 3 (SF 50190)

Exhibit three (3) of the five (5) kinds of honey listed below (#1-5) or prepare an educational display about honey bees or beekeeping (#6).

1. Extracted honey: Three (3) 1# jars (glass, screw-top), holding 1# of honey each.
2. Chunk honey (comb in a jar): Three (3) 1# jars (wide-mouth, glass).
3. Cut-comb honey: Three (3) 1# boxes (boxes are usually 4 ½" x 4 ½" in size).
4. Comb honey: Three (3) sections (honey built by bees in frames of wood commonly called "sections") (boxes are usually 4 ½" x 4 ½" in size).
5. Section honey: Three (3) sections of comb honey (in basswood boxes or Ross rounds) **OR**

6. Prepare an educational display about honey bees or beekeeping.

Entomology Beekeeping Ready4Life Challenge

For Ready4Life Career & Entrepreneurship Exploration exhibit opportunities for this project area, visit the Ready4Life section of this document.

ESPORTS

Each county may submit 3 entries from 50378.

All exhibitors must complete all activities in the Illinois 4-H eSports Pilot Curriculum.

eSports (SF 50378)

Compete in at least 1 ranked tournament online or in person (either as a team or solo), and fully document your progress throughout. Any game with a documentable bracket system, and at least 3 rounds counts. Be sure to include a description of the tournament, your match information, your win-loss record, and description of the game and platform being used to play the game (Ram requirements/capabilities of your machine, video card specs., etc.). Prepare a PowerPoint presentation describing your journey through eSports (including your 1 mandatory tournament), what you have learned about gaming/eSports, and why you think more youth should be involved. Also include a detailed description of your most important win, explaining your strategy in that victory. Be sure to include screenshots and video, if possible. Load your presentation to a USB drive.

EXPLORATORY (not eligible for state fair)

Exploratory (Welcome to 4-H) (not eligible for state fair)

Youth ages 8 – 10 may exhibit a display on one of the following topics from the project book:

- Windowsill gardening; **OR**
- 4-H animals; **OR**
- 4-H family; **OR**
- Coat of arms

Collectibles (not eligible for state fair)

Bring your completed project book and your collection or examples of your collection (if it's too large to bring) with pictures of total collection, OR an exhibit or poster illustrating one feature of the project.

Bicycle 1 (not eligible for state fair)

Exhibitors will draw three situations from a bag that relate to activities from Level 1 and discuss/explain all three with the judge. Situations may include: selecting bicycle safety equipment; demonstrate how to fit a helmet; identify bike parts and their function; selecting the right size bike; how to check bicycle tires, brakes and chains; recognizing traffic signs and their meaning; general discussion of bicycling hazards; and items to consider when planning a bike trip.

Bicycle 2 (not eligible for state fair)

Exhibitors will draw three situations from a bag that relate to activities from Level 2 and discuss/explain all three with the judge. Situations may include: factors to consider when choosing a bike; comparing tire pressure, valve type and tread; steps in fixing a flat tire; steps to follow when cleaning, lubricating and replacing a bike chain; evaluating the braking system on a bicycle; factors to consider when mapping out a bike route; rules for smart bike riding; and planning a menu for an all-day bike ride.

FAMILY HERITAGE

Each county may submit 1 entry from 50197.

Family Heritage (SF 50197)

Prepare an exhibit of items, pictures, maps, charts, slides/tapes, drawings, illustrations, writings or displays that depict the heritage of the member's family or community or 4-H history. Please note: Exhibits are entered at 4-H'ers own risk. 4-H is not responsible for loss or damage to family heirloom items or any items in this division. Displays should not be larger than

36 x 48 wide.

Family Heritage Ready4Life Challenge

For Ready4Life Career & Entrepreneurship Exploration exhibit opportunities for this project area, visit the Ready4Life section of this document.

FOODS & NUTRITION

Each county may submit 7 entries total from any of these food classes: 50200 a-c, 50201 a-c, 50202a-e, 50203a-d, 50204, 50206, 50208a-f, 50211.

4-H Cooking 101 (SF 50200a, 50200b, 50200c)

Using the recipes included in the project manual (which are also available at go.illinois.edu/Cooking101Recipes), prepare an exhibit for **one** of the classes below. No icing should be on any products. **No ingredient additions or substitutions should be made to the recipes**, unless they are to accommodate food allergies, sensitivities, or special diets (i.e. nut allergy, gluten intolerance, vegetarian/vegan diet, etc.). If you make changes to the recipe due to the reasons listed above, bring a copy of the recipe with your changes and be prepared to discuss them with the judge. Bars, coffeecake, or cookies should be displayed on a disposable plate placed in a zip-sealing plastic bag. In addition to your food exhibit, complete the What's on Your Plate? Activity on pages 10-11 in the 4-H Cooking 101 project manual (and for download at go.illinois.edu/Cooking101Activity). Bring a document with printed pictures of your 3 or more plates and the answers to questions 1-7 to remain on display with your project. The words on the plates must be legible and clearly visible in the picture. Pictures, graphics or photos are acceptable. Due to space limitations at State Fair, the size of the activity document should be no larger than an 8 ½" x 11" binder or folder.

Cereal Bars (SF 50200A) - 3 cereal marshmallow bars

Coffeecake (SF 50200B) - ¼ of 8" square or round coffeecake

Cookies (SF 50200C) - 3 cookies

Youth interested in exhibiting a food item from the project book not listed above, making changes to the provided recipes, or exhibiting a display related to information in the project manual should investigate the Foods Innovation class.

4-H Cooking 201 (SF 50201a, 50201b, 50201c)

Using the recipes included in the project manual (which are also available at go.illinois.edu/Cooking201Recipes), prepare an exhibit for **one** of the classes below. **No ingredient additions or substitutions should be made to the recipes**, unless they are to accommodate food allergies, sensitivities, or special diets (i.e. nut allergy, gluten intolerance, vegetarian/vegan diet, etc.). If you make changes to the recipe due to the reasons listed above, bring a copy of the recipe with your changes and be prepared to discuss them with the judge. Bread, biscuits, or scones should be displayed on a disposable plate placed in a zip-sealing plastic bag. In addition to your food exhibit, complete Experiment with Meal Planning Activity on page 91 in the 4-H Cooking 201 project manual (and for download at go.illinois.edu/Cooking201Activity). Bring either page 91 with your completed answers or a document with the answers to remain on display with your project along with a picture of the meal you prepared. You do not need to complete the Challenge Yourself section on page 91. Due to space limitations at State Fair, the size of the activity document should be no larger than an 8 ½" x 11" binder or folder.

Biscuits (SF 50201a) - 3 rolled biscuits

Scones (SF 50201b) - 3 scones

Nut Bread (SF 50201c) - ½ loaf (9" x 5") of basic nut bread (no variations)

Youth interested in exhibiting a food item from the project book not listed above, making changes to the provided recipes, or exhibiting a display related to information in the project manual should investigate the Foods Innovation class.

4-H Cooking 301 (SF 50202a, 50202b, 50202c, 50202d, 50202e)

Using the recipes included in the project manual (which are also available at go.illinois.edu/Cooking301Recipes), prepare an exhibit for **one** of the classes below. If icing is used on the tea ring or sweet rolls, the recipe for the icing must also come from the book. The yeast bread/roll dough may be prepared in a bread making machine; however prepared mixes are not permitted. **No ingredient additions or substitutions should be made to the recipes**, unless they are to accommodate food

allergies, sensitivities, or special diets (i.e. nut allergy, gluten intolerance, vegetarian/vegan diet, etc.). If you make changes to the recipe due to the reasons listed above, bring a copy of the recipe with your changes and be prepared to discuss them with the judge. Display exhibit on a disposable plate or pie tin and place in a zip-sealing plastic bag. In addition to your food exhibit, complete one of the six experiments: Experiment with Flour p. 33-34, Experiment with Kneading p. 35-36, Experiment with Yeast p. 37-38 or 39, Experiment with Butter p. 62-63 or Experiment with Cheese p. 104-105. Copies of all experiments are available to download at go.illinois.edu/Cooking301Experiments. Bring a document with a printed picture of your experiment and the answers to the experiment questions to remain on display with your project. Due to space limitations at State Fair, the size of the experiment document should be no larger than an 8 ½" x 11" binder or folder.

Dinner Rolls (50202a) - 3 dinner rolls

Yeast Bread (50202b) - loaf of yeast bread

Tea Ring (50202c) - 1 tea ring

Sweet Rolls (50202d) - 3 basic sweet dough rolls

Cake (50202e) - one layer of a rich white cake or rich chocolate cake, top side up (*without frosting*)

4-H Cooking 401 (SF 50203a, 50203b, 50203c, 50203d)

Using the recipes included in the project manual (*which are also available at go.illinois.edu/Cooking401Recipes*), prepare an exhibit for **one** of the classes below. **No ingredient additions or substitutions should be made to the recipes, unless they are to accommodate food allergies, sensitivities, or special diets (i.e. nut allergy, gluten intolerance, vegetarian/vegan diet, etc.).** If you make changes to the recipe due to the reasons listed above, bring a copy of the recipe with your changes and be prepared to discuss them with the judge. Display exhibit on a disposable plate and place in a zip-sealing plastic bag. In addition to your food exhibit, pick one of the recipes from Cooking 401 that is not a choice for exhibit. Make the recipe and take a picture of the results. Bring a document with a printed picture of the food you made from the recipe and the answers to the following two questions: 1.) If you made this recipe again, what would you do differently? 2.) What did you learn that can help you in other ways besides preparing food? Due to space limitations at State Fair, the size of the activity document should be no larger than an 8 ½" x 11" binder or folder.

Focaccia Bread (50203a) - ¼ of a 15" x 10" loaf of focaccia bread (do not include dipping oil)

Pie Shell (50203b) - one baked pie shell – traditional, oil, or whole wheat (no graham cracker)

Sponge Cake (50203c) - ¼ golden sponge cake, top side up, without frosting

French Bread (50203d) - ½ loaf French bread

Youth interested in exhibiting a food item from the project book not listed above, making changes to the provided recipes, or exhibiting a display related to information in the project manual should investigate the Foods Innovation class.

Food Science 1-4 (SF 50204)

Prepare a display, digital presentation, or poster on one of the food science experiments from the manual that you completed. Share 1) the food science question you investigated; 2) process used to conduct the experiment; 3) results and observations; 4) what you learned; and 5) how you have applied this information. You must furnish any equipment you need for the exhibit. Internet service is not provided. All exhibits must include something visual, such as a printed copy of a digital presentation. Electronic equipment will only be used during your judging time and will not remain on display during the exhibit period.

Sports Nutrition (SF 50206)

Prepare a display, digital presentation, or poster on one of the activity chapters in the manual that you completed. The activity chapters are listed by page number in the table of contents. Your exhibit should include, at minimum, information on one physical fitness component and one food/recipe component from the activity chapter. The exhibit should include the project manual with the pages of the activity completed. You may also include live demonstration of physical activities. Do not bring food made using the recipes, but consider adding pictures of the completed recipes to your exhibit. You must furnish any equipment you need for the exhibit. Internet service is not provided. All exhibits must include something visual,

such as a printed copy of a digital presentation. Electronic equipment will only be used during your judging time and will not remain on display during the exhibit period.

Examples for Activity 1

Example A: Make a video of yourself practicing flexibility, strength and endurance physical fitness activities and making pasta salad with different vegetable, pasta and dressing ideas. Bring a screenshot and brief description of your video to leave on display.

Example B: Make a poster of pictures of flexibility, strength and endurance physical fitness activities and information on the results of making the spinach and mandarin orange salad. Include answers to the questions in the book.

Food Preservation (SF 50208A, 50208B, 50208C, 50208D, 50208E, 50208F)

Prepare an exhibit using ONE of the following food preservation methods: canning; freezing; drying; pickles/relishes; jams, jellies and preserves **OR** a combination of these (see Preservation Combination option below), excluding Freezing. **No freezer jam exhibits will be allowed for Freezing; Jams, Jellies, and Preserves; or for the Preservation Combination options.** Be sure to review all of the Food Preservation rules that follow the class list so you can follow all exhibit requirements.

Fruits/Vegetables (SF 50208A) – The exhibit should include two different canned foods in appropriate jars for the products. Food may be fruit, vegetable, or tomato product (i.e. salsa, juice, etc.).

Freezing (SF 50208B) – Prepare a nutrition display that illustrates a freezing principle. There is NOT a food exhibit option for this preservation method.

Drying (SF 50208C) – Exhibit two (2) different dried foods packed in plastic food storage bags. Choose from fruit, vegetable, fruit leather or meat jerky.

Pickles and Relishes (SF 50208D) – Exhibit two (2) pint jars of different recipes of pickles and/or relishes made from produce.

Jams, Jellies, and Preserves (SF 50208E) – Exhibit two (2) half-pint jars of two different jams, jellies, and/or preserves.

Preservation Combination (SF 50208F) – Exhibit two (2) different preserved food products from two different categories above, excluding Freezing, in appropriate jars/packaging (Drying). For example, exhibit 1 jar of tomatoes (Fruits/Vegetables) and 1 half-pint of jelly (Jams, Jellies, and Preserves).

All preserved products should be prepared and processed according to the current USDA/Extension information. USDA information on preserving food, including recipes, can be found at: www.homefoodpreservation.com or <https://extension.illinois.edu/food/food-preservation>. Recipes must be processed in a water-bath or pressure canner. **Per the 4-H general show rules, entries must be produced (preserved) this 4-H year (between September 1, 2023 and August 31, 2024).**

All food preservation exhibits must be labeled with: 1) The name of the food; 2) The date preserved; 3) Appropriate method(s) of food preservation (For canned projects: boiling water bath or pressure canner; For drying projects: Specify equipment used (food dehydrator, oven, etc.)).

Examples:

- Strawberry jam, boiling water bath. July 13, 2024.
- Green beans, pressure canner. July 13, 2024.
- Beef jerky, food dehydrator and oven. July 13, 2024.

All food preservation exhibits must be accompanied with the recipe(s) – typed or written, with the source of the recipe(s) listed. **Required recipes and sources for food preservation exhibits** – all food preservation recipes must be from an approved source. Those sources are:

- *PUT IT UP! Food Preservation for Youth* website or manuals

- National 4-H Home Food Preservation Project Manuals
- U.S. Department of Agriculture (USDA)
- National Center for Home Food Preservation
- Ball/Kerr Canning (recipes after 1985)
- Mrs. Wages

DO NOT BRING RECIPES FROM: Magazine or newspaper clippings, Pinterest (unless it is from a source listed above), a recipe from a family member or friend without a source, cookbooks (excluding the Ball, Kerr, Put It Up!, and 4-H Home Food Preservation books).

Canning Equipment Requirements: All canned products must be canned in clear, standard jars in good condition (no chips or cracks). Jars must be sealed using two-piece canning lids (flat lid and band). Must use a new, unused flat lid. Bands must not be rusty or severely worn.

Foods Innovation Class (SF 50211)

Open to youth enrolled in any Foods project.

Demonstrate the skills and knowledge you have gained through the project. The exhibit may include, but isn't limited to, original recipes, results of experiments not in the foods project books, variations on recipes or experimenting with unique cooking or baking methods. Your work can be displayed by a food product, demonstrations, digital presentations, performances, or posters which you have made. Choose whatever method best shows what you've learned. Your exhibit should not fit in the other exhibit options for this project. You must furnish any equipment you need for your exhibit. Internet service will not be provided for the exhibit. All exhibits must include something visual, such as a printed copy of a digital presentation, which will remain on display during the exhibition. Electronic equipment will only be used during your personal judging time and will not remain on display during the entire exhibit period. If you bring a food product, the food will NOT be tasted.

Foods Nutrition Ready4Life Challenge

For Ready4Life Career & Entrepreneurship Exploration exhibit opportunities for this project area, visit the Ready4Life section of this document.

FORESTRY

Each county may submit 2 entries total from 50212, 50213, 50214, 50215

Forests of Fun 1 (SF 50212)

Exhibit any product or display illustrating an activity from the book. The exhibit may include, but isn't limited to, original works, objects, demonstrations, digital presentations, programs, websites, games, apps, performances, or posters which you have made. Choose whatever method best shows what you've learned. You must furnish any equipment you need for your exhibit. Internet service will not be provided for the exhibit. All exhibits must include something visual, such as a printed copy of a digital presentation, which will remain on display during the exhibition. Electronic equipment will only be used during your personal judging time and will not remain on display during the entire exhibit period.

Forests of Fun 2 (SF 50213)

Exhibit any product or display illustrating an activity from the book. The exhibit may include, but isn't limited to, original works, objects, demonstrations, digital presentations, programs, websites, games, apps, performances, or posters which you have made. Choose whatever method best shows what you've learned. You must furnish any equipment you need for your exhibit. Internet service will not be provided for the exhibit. All exhibits must include something visual, such as a printed copy of a digital presentation, which will remain on display during the exhibition. Electronic equipment will only be used during your personal judging time and will not remain on display during the entire exhibit period.

Forests of Fun 3 (SF 50214)

Exhibit any product or display illustrating an activity from the book. The exhibit may include, but isn't limited to, original works, objects, demonstrations, digital presentations, programs, websites, games, apps, performances, or posters which you have made. Choose whatever method best shows what you've learned. You must furnish any equipment you need for your exhibit. Internet service will not be provided for the exhibit. All exhibits must include something visual, such as a printed copy of a digital presentation, which will remain on display during the exhibition. Electronic equipment will only be

used during your personal judging time and will not remain on display during the entire exhibit period.

Forestry Innovation Class (SF 50215)

Demonstrate the skills and knowledge you have gained through your Forestry project. Exhibit may be the result of knowledge gained from project manuals; independent study, interaction with natural resource or conservation professionals. The exhibit may include, but isn't limited to, original works, objects, demonstrations, digital presentations, programs, websites, games, apps, performances, or posters which you have made. Choose whatever method best shows what you've learned. Your exhibit should not fit in the other exhibit options for this project. You must furnish any equipment you need for your exhibit. Internet service will not be provided for the exhibit. All exhibits must include something visual, such as a printed copy of a digital presentation, which will remain on display during the exhibition. Electronic equipment will only be used during your personal judging time and will not remain on display during the entire exhibit period.

Forestry Ready4Life Challenge

For Ready4Life Career & Entrepreneurship Exploration exhibit opportunities for this project area, visit the Ready4Life section of this document.

GEOLOGY

Each county may submit 3 entries total from 50218, 50219, 50220, 50221, 50222.

The size and number of exhibit cases should relate appropriately to the number of specimens being displayed for a specified class. Specimens are not limited to Illinois locations. All levels of Geology use the same manual, *Geology-Introduction to the Study of the Earth*. **Do not identify your specimens any further than phylum and class.** There is one exception to this for fossils that are identified to phylum OR class. Class should only be used for fossils of mollusks, back-boned animals, and arthropods.

Pebble Pups 1 (SF 50218)

Display 8 to 19 rocks and mineral specimens with three minerals in the collection. Collection may include duplications that show variations. Label collection and note where found.

Pebble Pups 2 (SF 50219)

Display at least 20, but no more than 29, rocks and mineral specimens with seven minerals in the collection. Collection may include duplications that show variations. Label collection and note where found.

Rock Hounds 1 (SF 50220)

Display at least 30, but no more than 40, rocks and mineral specimens with ten minerals in the collection. Rocks should include at least three igneous, two metamorphic, and three sedimentary groups. Label collection and note where found.

Rock Hounds 2 (SF 50221)

Display no more than 50 specimens that have been selected to illustrate a specific theme of the exhibitor's choosing. Be creative. Sample categories could include (but are not limited to): industrial minerals and their uses; a specific rock group and the variety that occurs in that group, including some minerals that occur in that environment; select fossils traced through the geologic ages; minerals and their crystal habits; rocks and minerals used in the lapidary arts.

Geology Innovation Class (SF 50222)

Open to youth enrolled in Geology.

Demonstrate the skills and knowledge you have gained through the Geology project. Exhibit may be the result of knowledge gained from project manuals; independent study about Illinois rock(s) and mineral(s), interaction with geology professionals; and/or individual exploration in the area of geology. The exhibit may include, but isn't limited to, original works, objects, demonstrations, digital presentations, programs, websites, games, apps, performances, or posters which you have made. Choose whatever method best shows what you've learned. Your exhibit should not fit in the other exhibit options for this project. You must furnish any equipment you need for your exhibit. Internet service will not be provided for the exhibit. All exhibits must include something visual, such as a printed copy of a digital presentation, which will remain on display during the exhibition. Electronic equipment will only be used during your personal judging time and will not remain on display during the entire exhibit period.

Geology Ready4Life Challenge

For Ready4Life Career & Entrepreneurship Exploration exhibit opportunities for this project area, visit the Ready4Life section of this document.

Goats ([Dairy](#), [Meat](#))

See Animal Science for non-livestock project or LIVESTOCK section for LIVE animal shows.

[HEALTH](#)

Each county may submit 3 entries total from 50226, 50227, 50228, 50229, 50230.

All display boards must include a reference list indicating where information was obtained, giving credit to the original author, to complete the 4-H member's exhibit. This reference list should/might include website links, people and professionals interviewed, books, magazines, etc. This reference list should be attached to the back of a poster or display board or included as part of the display visible to the public. A judge is not to discredit an exhibit for the way references are listed. Display boards should be no larger than 36 x 48.

Health 1 (SF 50226)

Create an educational poster/display about any health topic of choice that is age/grade appropriate. Another option is to create a family first aid kit, emergency kit, an emergency kit to take on camping, hiking, biking, etc.

Health 2 (SF 50227)

Create an educational poster or display about any health topic of choice that is age/grade-appropriate. Another option is to create a personal nutrition kit to use when doing physical activity like chores, working out at the gym, hiking, biking, skiing, or another similar kit.

Health 3 (SF 50228)

Create an educational poster or display about any health topic of choice that is age/grade appropriate. Another option is to create an activity or guide to help yourself or others become more aware of financial wellness, mental health, disease prevention, or other similar topic that promotes healthy habits.

Your Thoughts Matter – Navigating Mental Health (SF 50230)

Prepare an exhibit that demonstrates the knowledge and understanding gained through completion of the Your Thoughts Matter Member Project Guide. Exhibit the following 1) a poster or display that highlights activities and knowledge gained as you completed any two of activities 1 – 9 included in the curriculum; AND 2) the item you created in Activity 10 - the flyer, website, video, or other promotional tool that points individuals to the resources you found.

Health Innovation Class (SF 50229)

Open to youth enrolled in Health 1, 2 or 3.

Demonstrate the skills and knowledge you have gained through the Health project. **Your exhibit should not fit in the other exhibit options for this project.** The exhibit may include, but isn't limited to, original works, objects, demonstrations, digital presentations, programs, websites, games, apps, performances, or posters which you have made. Choose whatever method best shows what you've learned. You must furnish any equipment you need for your exhibit. Internet service will not be provided for the exhibit. All exhibits must include something visual, such as a printed copy of a digital presentation, which will remain on display during the exhibition. Electronic equipment will only be used during your personal judging time and will not remain on display during the entire exhibit period.

Health Ready4Life Challenge

For Ready4Life Career & Entrepreneurship Exploration exhibit opportunities for this project area, visit the Ready4Life section of this document.

[HORSE](#)

See Animal Science for non-livestock project or LIVESTOCK section for LIVE animal shows.

[HORTICULTURE: FLORICULTURE](#)

Each county may submit 3 entries total from 50192, 50193, 50194, 50195, 50196.

Floriculture A (SF 50192)

Exhibit one of the following options. **Please note that flower arrangements, including the vase or container, must be no larger than 12"x 12".**

- Create a flower arrangement, either a round arrangement or a bud vase. No silk flowers are permitted; **OR**
- Create a photo collage or a collection of pictures of flowers that you have raised. Label your flowers by name and tell if you started with a seed, cutting or transplants. Mount pictures on a poster board; **OR**
- Exhibit in one container: 3 stems of blooms - each with attached foliage. Foliage that would go inside the container may be removed. All three blooms or stems should be the same variety, color, shape and size and must have been grown from seed, young seedling plants, bulbs or rhizomes by the exhibitor. (NOTE: Exhibitors choosing lilies should include no more than 2/3 of foliage for their exhibit.)

Floriculture B (SF 50193)

Exhibit one of the following options:

- Display a mixed planter that may include herbs with foliage plants and/or flowering plants. The planter should include three or more kinds of plants. The container exhibit space must not exceed 18"x18".
- Create an artistic display of dried flowers and/or herbs explaining how each was dried; **OR**
- Create a photo collage or collection of pictures of plants from your theme garden. Label your plants by name and explain how the plants were chosen to fit the theme.
- Create an artistic fairy garden of plants, flowers and/or herbs. Explain the process you utilized to prepare your fairy garden. Label your plants by name and explain how the plants were chosen to fit the theme.

Floriculture C (SF 50194)

Exhibit one of the following options:

- **Create a terrarium. The size of the terrarium should be appropriate for use on a table at home, and no larger than 12" deep, 18" long, and 16" high. Selected plants should be started by the exhibitor from cuttings or seeds or as purchased plugs. The terrarium must be cared for by the exhibitor for at least 5 months. Exhibitor should be able to explain the different plant, soil, and environmental needs and watering requirements of a closed system; OR**
- Exhibit a plant that you propagated from cuttings, layering or division or started from seed. Create a photo board showing the progression of growth. Tips for vegetative propagation of houseplants can be found in the University of Illinois Extension Gardener's Corner (go.illinois.edu/gardenerscorner).

Floriculture D (SF 50195)

Exhibit one of the following options. **The maximum size for exhibits in this category is 24"x24" X36".**

- Create a centerpiece around a theme such as a wedding, holiday, birthday, etc. No silk flowers are permitted; **OR**
- Create an exhibit of forced bulbs in a pot.

Floriculture Display (SF 50196)

(Open to youth enrolled in Floriculture A, Floriculture B, Floriculture C, and Floriculture D)

Present an exhibit of the member's choice that focuses on some aspect of floriculture which does not fit in the categories above. The exhibit may include, but isn't limited to, dish gardens, original works, objects, demonstrations, digital presentations, programs, websites, games, apps, performances, or posters which you have made. Choose whatever method best shows what you've learned. You must furnish any equipment you need for your exhibit. Internet service will not be provided for the exhibit. All exhibits must include something visual, such as a printed copy of a digital presentation, which will remain on display during the exhibition. Electronic equipment will only be used during your personal judging time and will not remain on display during the entire exhibit period.

Floriculture Ready4Life Challenge

For Ready4Life Career & Entrepreneurship Exploration exhibit opportunities for this project area, visit the Ready4Life section of this document.

HORTICULTURE: VEGETABLES, HERBS & FRUITS

Each county may submit 3 entries total for 50313, 50314, 50315, 50316, 50317.

All exhibits must have been grown by the exhibitor as part of their current gardening 4-H project. Exhibitors should be knowledgeable about various aspects of the produce, including but not limited to different varieties, soil testing, fertilizers used, etc. Exhibits should be prepared according to the Illinois Vegetable Garden Guide website: <https://extension.illinois.edu/gardening>. Waxes and oils may not be used on vegetables or fruits. Any plant infested with insects will be removed from the exhibit area and will not be eligible for champion awards.

Herb Container Display (SF 50313)

(Open to youth in Vegetable Gardening A (Level 1), Vegetable Gardening B (Level 2), Vegetable Gardening C (Level 3), and Vegetable Gardening D (Level 4))

Herbs should be grown in pots (8" maximum diameter). Categories: Mint, Oregano, Rosemary, Sage, Thyme, and all other herbs. Herbs should be labeled with common and Latin names. Herbs should be in your care for a minimum of three months for state fair exhibits. Remove dead leaves from plants and check that the soil is clear of debris such as dead leaves. When exhibiting herb plants, be sure to grow the plants in the container to be displayed to avoid transplant shock. Exhibits will be evaluated based on cleanliness, uniformity, condition, quality, and trueness to variety. Additional herb resources are located on the project resources section of the Illinois 4-H website.

- Display must include 4 or more different kinds of herbs. There may not be more than 2 different varieties of any herb. For example, peppermint and chocolate mint would be classified as two different herb varieties.
- In instances where containers display more than one variety of herb, special care should be taken that each distinct variety is accessible and clearly visible to the judges to ensure full points for cleanliness.

Vegetable/Fruit Display (SF 50314)

(Open to youth in Vegetable Gardening A, Vegetable Gardening B, Vegetable Gardening C, and Vegetable Gardening D)

1. This class is allowed a 2'6" x 2'6" space for each display.
2. Display must include 6 or more different kinds of vegetables or fruits. There may not be more than 2 different varieties of any vegetable/fruit. For example, red and white potatoes would be classified as two different varieties. Acorn squash and zucchini would be classified as two different vegetables.
3. The number and type of vegetables/fruits used must conform to the Vegetable/Fruit Plate/Display List. *Fruit Plate list is below Vegetable Plate list.*
4. Exhibitors must provide the name and variety of all vegetables/fruits used. (i.e. Cabbage – Golden Acre; Cucumber, slicing – Straight Eight; Tomatoes, slicing – Rocky Top; Snap Beans – Contender, etc.).

Vegetable Plates (SF 50315)

(Open to youth in Vegetable Gardening A, Vegetable Gardening B, Vegetable Gardening C, and Vegetable Gardening D)

1. Exhibit must include 2 single vegetable plates. (Exhibitor will furnish the disposable plates.)
2. Exhibitors must provide the name and variety of all vegetables/fruits used. (i.e. Cabbage – Golden Acre; Cucumber, slicing – Straight Eight; Tomatoes, slicing – Rocky Top; Snap Beans – Contender, etc.). Number of vegetables on plates must conform to plate list below.
3. Only one variety on each plate.
4. An exhibitor cannot show two plates of the same type vegetable. (i.e.: Cannot exhibit red *and* white potatoes or zucchini *and* straightneck summer squash.)

VEGETABLE PLATE/DISPLAY LIST

When selecting vegetables for exhibition, keep in mind that the judge will evaluate them on the basis of cleanliness, uniformity, condition, quality, and trueness to variety. (*Lists are provided by UI Extension Horticulturists; Items are listed according to the correct definition of vegetables*)

- | | | |
|-------------------------------------|----------------------------------|--|
| • Asparagus (5 spears) | • Eggplant (1) | • Peas, (12 pods) |
| • Beans, Lima (12 pods) | • Garlic (5) | • Peppers, large fruited (bell/banana) (5) |
| • Beets (5) | • Kohlrabi (5) | • Peppers, small fruited (chili/cherry) (12) |
| • Broccoli (1 head) | • Lettuce (1 head or plant) | • Popcorn (5) |
| • Brussels sprouts (12 sprouts) | • Muskmelon incl. cantaloupe (1) | • Potatoes (any variety) (5) |
| • Cabbage (1 head) | • Okra (12) | • Pumpkin (1) |
| • Cauliflower (1 head) | • Onions, large, dry (5) | • Rhubarb, trimmed stalks (3) |
| • Carrots (5) | • Onions, green or set (12) | • Rutabaga (5) |
| • Cucumber, pickling or slicing (5) | • Parsnips (5) | |

- Salsify (5)
- Squash, summer (any variety) (3)
- Squash, winter (Acorn, butternut, buttercup, spaghetti, Hubbard, Turks’s Turban) (1)
- Beans, Snap, Green Pod or Golden Wax (12 pods)
- Greens (collard, endive, escarole, kale, mustard, spinach, Swiss chard) (1 plant)
- Horseradish Root (1 marketable root specimen harvested this year)
- Sweet corn, in husks (5)
- Tomatoes, slicing (5)
- Tomatoes, small fruited
- (12)
- Turnip (5)
- Watermelon (1)

Vegetable Gardening Display - Other (SF 50316)

(Open to youth in Vegetable Gardening A, Vegetable Gardening B, Vegetable Gardening C, Vegetable Gardening D)

Present an exhibit of the member’s choice that focuses on some aspect of vegetable gardening which does not fit in the categories above. The exhibit may include, but isn’t limited to, original works, objects, demonstrations, digital presentations, programs, websites, games, apps, performances, or posters which you have made. Choose whatever method best shows what you’ve learned. You must furnish any equipment you need for your exhibit. Internet service will not be provided for the exhibit. All exhibits must include something visual, such as a printed copy of a digital presentation, which will remain on display during the exhibition. Electronic equipment will only be used during your personal judging time and will not remain on display during the entire exhibit period.

Fruit Plates (SF 50317)

(Open to youth in Vegetable Gardening A, Vegetable Gardening B, Vegetable Gardening C, and Vegetable Gardening D)

1. Exhibit must include 2 single fruit plates. (Exhibitor will furnish the disposable plates.)
2. Exhibitors must provide the name and variety of all vegetables/fruits used. Number of fruits on plates must conform to plate list below.
3. Only one variety on each plate.
4. An exhibitor cannot show two plates of the same type fruit. (i.e.: Cannot exhibit Gala & Jonathan Apples, Mazzard & Gisela Cherries, etc.)

FRUIT PLATE LIST

Fruit will be judged using the same general criteria used for vegetables. Fruit will be judged for the stage of maturity normal for that season and growing location. Emphasis will be placed on how well fruit approaches market quality. When selecting fruits for exhibition, keep in mind that the judge will evaluate them on the basis of cleanliness, uniformity, condition, quality, and trueness to variety. (Lists are provided by UI Extension Horticulturists; Items are listed according to the correct definition of fruit varieties at <https://extension.illinois.edu/fruit-trees>)

- Strawberries (Everbearers) – 1 pint
- Grapes – 2 bunches
- Apples – 5
- Pears – 5
- Wild Plums – 1 pint
- Other Small Fruit or Berries (Do not duplicate entries from the above fruits) – 1 pint
- Other Fruits or Nuts (Do not duplicate entries from the above fruits) – 5

Vegetable Gardening Ready4Life Challenge

For Ready4Life Career & Entrepreneurship Exploration exhibit opportunities for this project area, visit the Ready4Life section of this document.

INTERCULTURAL

Each county may submit 1 individual entry from 50233a; 1 individual entry from 50234a; 1 club entry from 50233b and one from 50234b. Due to space restrictions, exhibits are limited to 2' 6" wide and 15" deep.

Passport to the World, Individual (SF 50233a)

Prepare a display illustrating what you have learned about a country. This might include topics such as-geography, economy, agriculture, people, language, housing, culture, music, crafts, clothing, environment, or holidays. Exhibits can focus on one or two topics in depth or cover more topics in brief. Exhibit should be educational in nature and should not promote one's beliefs over another person's beliefs. The exhibit may include, but isn't limited to, original works, objects, demonstrations, digital presentations, programs, websites, games, apps, performances, or posters which you have made. Choose whatever method best shows what you've learned. You must furnish any equipment you need for your exhibit. Internet service will not be provided for the exhibit. All exhibits must include something visual, such as a printed copy of a digital presentation, which will remain on display during the exhibition. Electronic equipment will only be used during your personal judging time and will not remain on display during the entire exhibit period. Due to space restrictions, exhibits are limited to 2' 6" wide and 15" deep.

Passport to the World, Club (SF 50233b)

Exhibit a display illustrating what your club has learned about a country. This might include topics such as-geography, economy, agriculture, people, language, housing, culture, music, crafts, clothing, environment, or holidays. Exhibits can focus on one or two topics in depth or cover more topics in brief. Exhibit should be educational in nature and should not promote one's beliefs over another person's beliefs. The exhibit may include, but isn't limited to, original works, objects, demonstrations, digital presentations, programs, websites, games, apps, performances, or posters which you have made. Choose whatever method best shows what you've learned. You must furnish any equipment you need for your exhibit. Internet service will not be provided for the exhibit. All exhibits must include something visual, such as a printed copy of a digital presentation, which will remain on display during the exhibition. Electronic equipment will only be used during your personal judging time and will not remain on display during the entire exhibit period. The display must be accompanied by 3 or more club exhibitors at the time of the judge's critique. Club members should make a 5-7-minute presentation to the judge. All club members present for the judge's critique should be able to discuss the project and answer questions. Only club members present for judging who participate in the actual critique and presentation are eligible for ribbons and premiums. Cloverbuds are not eligible for state fair and cannot be promoted and participate in a group presentation at state fair. Due to space restrictions, exhibits are limited to 2' 6" wide and 15" deep.

Diversity & Cultural Awareness, Individual (SF 50234a)

Create a display or binder portfolio that illustrates the results of a minimum of three (3) completed activities from the project book. Due to space restrictions, exhibits are limited to 2' 6" wide and 15" deep.

Diversity & Cultural Awareness, Club (SF 50234b)

Exhibit a display illustrating the steps that the club has completed on the project selected for the year, including reflection on activities completed. Include a written outline or report of accomplishments and future goals. The exhibit may include, but isn't limited to, original works, objects, demonstrations, digital presentations, programs, websites, games, apps, performances, or posters which you have made. Choose whatever method best shows what the club members have learned. You must furnish any equipment you need for your exhibit. Internet service will not be provided for the exhibit. All exhibits must include something visual, such as a printed copy of a digital presentation, which will remain on display during the exhibition. Electronic equipment will only be used during your personal judging time and will not remain on display during the entire exhibit period. The display must be accompanied by 3 or more club exhibitors at the time of the judge's critique. Club members should make a 5-7-minute presentation to the judge. All club members present for the judge's critique should be able to discuss the project and answer questions. Only club members present for judging who participate in the actual critique and presentation are eligible for ribbons and premiums. Cloverbuds are not eligible for state fair and cannot be promoted and participate in a group presentation at state fair. Due to space restrictions, exhibits are limited to 2' 6" wide and 15" deep.

Intercultural Ready4Life Challenge

For Ready4Life Career & Entrepreneurship Exploration exhibit opportunities for this project area, visit the Ready4Life section of this document.

INTERIOR DESIGN

Each county may submit 2 entries total from 50242, 50243, 50244, 50245.

Design Decisions, Beginning (SF 50242)

Any exhibit must have been created or redesigned by the exhibitor as part of their current Interior Design 4-H project. Exhibitors should be knowledgeable about various aspects of the project. Exhibits could include items such as, but not limited to, comparison studies of different products or techniques; made accessories, wall-hangings, window coverings, or furniture items; refinished or redesigned furniture; or a plan to solve some type of interior design problem. Exhibit should be appropriate to the exhibitor's age, skills and ability in this project.

Design Decisions, Intermediate (SF 50243)

Any exhibit must have been created or redesigned by the exhibitor as part of their current Interior Design 4-H project. Exhibitors should be knowledgeable about various aspects of the project. Exhibits could include items such as, but not limited to, comparison studies of different products or techniques; made accessories, wall-hangings, window coverings, or furniture items; refinished or redesigned furniture; or a plan to solve some type of interior design problem. Exhibit should be appropriate to the exhibitor's age, skills and ability in this project.

Design Decisions, Advanced (SF 50244)

Any exhibit must have been created or redesigned by the exhibitor as part of their current Interior Design 4-H project. Exhibitors should be knowledgeable about various aspects of the project. Exhibits could include items such as, but not limited to, comparison studies of different products or techniques; made accessories, wall-hangings, window coverings, or furniture items; refinished or redesigned furniture; or a plan to solve some type of interior design problem. Exhibit should be appropriate to the exhibitor's age, skills and ability in this project.

Interior Design Innovation Class (SF 50245)

Open to enrolled in Interior Design.

Demonstrate the skills and knowledge you have gained through the Interior Design project. The exhibit may include, but isn't limited to, original works, objects, demonstrations, digital presentations, programs, websites, games, apps, performances, or posters which you have made. Choose whatever method best shows what you've learned. Your exhibit should not fit in the other exhibit options for this project. You must furnish any equipment you need for your exhibit. Internet service will not be provided for the exhibit. All exhibits must include something visual, such as a printed copy of a digital presentation, which will remain on display during the exhibition. Electronic equipment will only be used during your personal judging time and will not remain on display during the entire exhibit period.

Interior Design Ready4Life Challenge

For Ready4Life Career & Entrepreneurship Exploration exhibit opportunities for this project area, visit the Ready4Life section of this document.

LEADERSHIP

Each county may submit 3 entries total from 50249, 50250, 50251, 50252; 2 entries from 50254.

Leadership 1 (SF 50249)

Create a binder portfolio with a minimum of four (4) completed activities each year from the areas noted below. Build upon

your previous year's work. Photocopies or original pages of the completed activities from the book should be included in the portfolio.

- **First Year** – One activity from each of the following sections: Understanding Self; Communication; and Getting Along with Others, plus one activity of exhibitor's choice from the manual.
- **Second Year** – One activity from each of the following sections: Getting Along with Others; Learning to Learn; and Making Decisions, plus one activity of exhibitor's choice from the manual.
- **Third Year** – One activity from each of the following sections: Making Decisions; Managing; and Working with Groups, plus one activity of exhibitor's choice from the manual.

Leadership 2 (SF 50250)

Building upon your previous work, continue adding to your binder portfolio with a minimum of four (4) completed activities each year from the areas noted below. Photocopies or original pages of the completed activities from the book should be included in the portfolio.

- **First Year** – One activity from each of the following sections: Understanding Self; Communication; and Getting Along with Others, plus one activity of exhibitor's choice from the manual.
- **Second Year** – One activity from each of the following sections: Getting Along with Others; Learning to Learn; and Making Decisions, plus one activity of exhibitor's choice from the manual.
- **Third Year** – One activity from each of the following sections: Making Decisions; Managing; and Working with Groups, plus one activity of exhibitor's choice from the manual.

Leadership 3 (SF 50251)

Building upon your previous work, continue adding to your binder portfolio with a minimum of four (4) completed activities each year from the areas noted below. Photocopies or original pages of the completed activities from the book should be included in the portfolio.

- **First Year** – One activity from each of the following sections: Understanding Self; Communication; and Getting Along with Others, plus one activity of exhibitor's choice from the manual.
- **Second Year** – One activity from each of the following sections: Getting Along with Others; Learning to Learn; and Making Decisions, plus one activity of exhibitor's choice from the manual.
- **Third Year** – One activity from each of the following sections: Making Decisions; Managing; and Working with Groups, plus one activity of exhibitor's choice from the manual.

Leadership Innovation Class (SF 50252)

Open to youth enrolled in Leadership 1, 2, or 3.

Demonstrate the skills and knowledge you have gained through the Leadership project. **Your exhibit should not fit in the other exhibit options for this project.** The exhibit may include, but isn't limited to, original works, objects, demonstrations, digital presentations, programs, websites, games, apps, performances, or posters which you have made. Choose whatever method best shows what you've learned. You must furnish any equipment you need for your exhibit. Internet service will not be provided for the exhibit. All exhibits must include something visual, such as a printed copy of a digital presentation, which will remain on display during the exhibition. Electronic equipment will only be used during your personal judging time and will not remain on display during the entire exhibit period.

Leadership Group Exhibit (SF 50254)

Open to clubs and groups whose members are enrolled in any Leadership project

Exhibit a display illustrating how your group has used the Teens As Leaders model effectively in your club, community, school, or state. Leadership activities might include planning, advising, promoting, mentoring, teaching or advocating for change. The exhibit may include, but isn't limited to, original works, objects, demonstrations, digital presentations, programs, websites, games, apps, performances, or posters which you have made. Choose whatever method best shows what you've learned. You must furnish any equipment you need for your exhibit. Internet service will not be provided for the exhibit. All exhibits must include something visual, such as a printed copy of a digital presentation, which will remain on

display during the exhibition. Electronic equipment will only be used during your personal judging time and will not remain on display during the entire exhibit period. The display must be accompanied by 3 or more 4-H members at the time of the judge's critique. Club members should make a 5- to 10-minute presentation to the judge. All club members present for the judge's critique should be able to discuss the project and answer questions. Only club members present for judging who participate in the actual critique and presentation are eligible for ribbons and premiums. Cloverbuds are not eligible for state fair and cannot be promoted and participate in a group presentation at state fair. Due to space limitations, exhibits are limited to 2'6" wide and 15" deep. More information on Teens as Leaders Model found here:

<https://go.illinois.edu/LeadershipModel>.

Leadership Ready4Life Challenge

For Ready4Life Career & Entrepreneurship Exploration exhibit opportunities for this project area, visit the Ready4Life section of this document.

MAKER

Each county may submit 3 entries from 50400.

Maker: Open to youth in all projects. (SF 50400)

Exhibits in this category are designed to be multi-disciplinary in nature, innovative, and must not fit into any other exhibit category. **To qualify for this category, your project MUST abide by the following guidelines:**

- Exhibitors must complete the DIY Make & Build Curriculum, and answer all the questions at the end of each lesson. You must display (or upload if virtual) your answers to these questions, as well as your Maker Log from the DIY Make and Build curriculum.
- Exhibits must be an object or device that has an intended purpose and uses technology in either a mechanical way, digital (computer) way, or combination of the two. Your device or object **cannot** be one of the included activities in the DIY Make and Build Curriculum.
- The device must be something that can be used in everyday life by multiple people (a target audience), and **MUST** be manufactured/built by the exhibitor (If not fully manufactured by the exhibitor, the device **MUST** be modified structurally or be reprogramed to perform a different function other than what it was designed to do).
- Exhibits **MUST** be able to interact with the outside world. (e.g. an on off switch, input sensors, feedback, etc.)
- Exhibits **MUST** include a detailed build log with instructions on how to make or build the exhibit, **AND** contain either a 3D rendering or detailed and labeled sketches of the device/product.
- All parts and software used in the design/build **MUST** be listed in a detailed Bill of Materials including cost per item and total cost. Total time spent on the build must be documented in your build log.

In addition, exhibitors are **HIGHLY** encouraged to use tools such as 3-D printers, laser cutters, routers and/or other hand/power tools to help in the manufacturing process (**NOTE: Simply 3-D printing or laser cutting an object without the other specifications does not qualify as a Maker Project**). It is also **HIGHLY** encouraged that exhibits use Open Source software and/or hardware in the build.

NATURE: NATURAL RESOURCES AND OUTDOOR ADVENTURES

Each county may submit 3 entries from 50256, 50257, 50258, 50259, 50267a, 50267b, 50278.

Electricity and water are **NOT** available for these displays. **NO live animals or reptiles are permitted in these exhibits.**

Exploring Your Environment 1 (SF 50267a)

Exhibit any item, project, or display made as it relates to an activity in the *Exploring Your Environment - Ecosystem Services* project manual (product #08410). The display should demonstrate an understanding of natural and/or manmade environments, how humans affect the environment, or how the environment affects our lives. Include your project manual that documents activity recordkeeping, your answers to activity questions, and details personal thoughts and ideas.

Exploring Your Environment 2 (SF 50267b)

Exhibit any item, project, or display made as it relates to an activity in the *Exploring Your Environment – Earth’s Capacity* project manual (product #08411). The display should demonstrate an understanding of one of the following: stewardship of natural resources, investigating greenhouse effects on living organisms, methods of reducing or managing waste in your home or community, or calculating your ecological footprint. Include your project manual that documents activity recordkeeping, your answers to activity questions, and details personal thoughts and ideas.

Natural Resources 1 (SF 50256)

Exhibit any item developed from the project book, *Step Into Nature*.

Natural Resources 2 (SF 50257)

Exhibit any item developed from the project book, *Explore the Natural World*.

Natural Resources 3 (SF 50258)

Exhibit any item developed from the project book, *Blaze the Trail*.

Outdoor Adventures 1-3 (SF 50259)

Exhibit a display illustrating an activity completed from the project manual.

Natural Resources or Outdoor Adventures Innovation Class (SF 50278)

Open to youth enrolled in any Natural Resources or Outdoor Adventures project.

Demonstrate the skills and knowledge you have gained through your Natural Resources or Outdoor Adventures project. Exhibit may be the result of knowledge gained from project manuals; independent study, interaction with natural resource or conservation professionals. The exhibit may include, but isn’t limited to, original works, objects, demonstrations, digital presentations, programs, websites, games, apps, performances, or posters which you have made. Choose whatever method best shows what you’ve learned. Your exhibit should not fit in the other exhibit options for this project. You must furnish any equipment you need for your exhibit. Internet service will not be provided for the exhibit. All exhibits must include something visual, such as a printed copy of a digital presentation, which will remain on display during the exhibition. Electronic equipment will only be used during your personal judging time and will not remain on display during the entire exhibit period.

Natural Resources Ready4Life Challenge

For Ready4Life Career & Entrepreneurship Exploration exhibit opportunities for this project area, visit the Ready4Life section of this document.

NATURE: FISHING AND WILDLIFE

Each county may submit 3 entries total from 50260, 50261, 50262, 50266, 50263, 50264, 50265.

Sportsfishing 1 (SF 50260)

Exhibit a product or display made to complete an activity in the *Take the Bait* project manual. This could include, but is not limited to, displays on: different types of fishing tackle, identifying different baits and their uses (no actual bait, please) or identifying the anatomy of a fish. For safety reasons, lures must be placed in a plastic case.

Sportsfishing 2 (SF 50261)

Exhibit a product or display made to complete an activity in the *Reel in the Fun* project manual. This could include, but is not limited to, displays on: different types of knots or rigs and their use; a collection of fishing lures, labeled with their use; or information on preparing and cooking fish (not recipes). For safety reasons, lures must be placed in a plastic case.

Sportsfishing 3 (SF 50262)

Exhibit a product or display made to complete an activity in the *Cast into the Future* project manual. This could include, but is not limited to, displays on: making artificial flies and lures; researching effects of water temperature; sportsfishing careers; or identifying insects that fish eat. For safety reasons, lures must be placed in a plastic case.

Wildlife 1 (SF 50266)

Exhibit any activity developed from the project manual. Be able to explain the importance of and concept behind the exhibit.

Wildlife 2 (SF 50263)

Exhibit any activity developed from the project manual. (Ex. Create a display of the life history of an animal.) Within the exhibit, explain the importance of and concept behind the exhibit.

Wildlife 3 (SF 50265)

Exhibit any activity developed from the project manual. Be able to explain the importance of and concept behind the exhibit.

Fish and Wildlife Innovation Class (SF 50264)**Open to youth enrolled in any Sportfishing or Wildlife project.**

Demonstrate the skills and knowledge you have gained through your Sportsfishing or Wildlife project. Exhibit may be the result of knowledge gained from project manuals; independent study, interaction with natural resource or conservation professionals. The exhibit may include, but isn't limited to, original works, objects, demonstrations, digital presentations, programs, websites, games, apps, performances, or posters which you have made. Choose whatever method best shows what you've learned. Your exhibit should not fit in the other exhibit options for this project. You must furnish any equipment you need for your exhibit. Internet service will not be provided for the exhibit. All exhibits must include something visual, such as a printed copy of a digital presentation, which will remain on display during the exhibition. Electronic equipment will only be used during your personal judging time and will not remain on display during the entire exhibit period.

Fishing & Wildlife Ready4Life Challenge

For Ready4Life Career & Entrepreneurship Exploration exhibit opportunities for this project area, visit the Ready4Life section of this document.

PHOTOGRAPHY

Each county may submit 3 entries total from 50268, 50269, 50270, 50271

ALL photos in exhibits must have been taken by the exhibitor. Photo/Model releases from individuals pictured in the exhibitor's photographs are required unless the photograph is of a group in a public place where identification would not be an issue. **Meta data must be included on the back of the picture. The photo release and meta data tip sheet can be obtained at: <https://go.illinois.edu/PhotographyProject>.** Photos may be taken with a camera, an electronic tablet (i.e. iPad), or a cell phone.

ALL photos must be accompanied by details of the camera settings that include:

- Camera/device used
- Aperture (F-stop)
- Exposure time (shutter speed)

- ISO (film/sensor sensitivity)
- Lighting used (flash, artificial, sunlight, other)
- Lens Filters (Ultra-Violet, Polarizing, etc.) if used.

Additional details required for Photo Editing ONLY:

- Photo editing software/application used (required for ALL edits and retouches except for cropping)
- Filters used (lens filters and or digital/software filters)

Members are allowed to shoot on a camera's automatic setting, but should be able to find the metadata information on the photo to discuss the information above.

The exhibition size requirements for all photographs will be:

- Minimum image size: 5" x 7"
- Maximum image size: 8" x 10"
- Maximum exhibit size (including frame): 18" x 20"

All exhibitors must include unframed (taped to the back of the framed exhibit or attached to the project booklet) **original or un-edited** versions of either the same subject or the examples of the same technique that the framed image represents. This will assist the judge in understanding the choices made by the photographer to build the exhibited composition.

NOTE: Images taken with devices that apply an automatic filter will not be eligible for award.

Photography 1 (SF 50268)

Exhibit one framed photo which demonstrates your understanding of a technique you learned from your Photography 1 project manual. No photo editing is allowed in this class except cropping and red eye removal. Be prepared to show the page in the manual of the technique you are demonstrating.

Photography 2 (SF 50269)

Exhibit one of the options listed below:

- Exhibit one framed 8" x 10" close-up photograph using the skills learned on pages 58-61(section: Bits and Pieces) of the project manual titled *Level 2 Next Level Photography*. No photo editing is allowed in this class except cropping and red eye removal. **Be prepared to show the page in the manual of the technique you are demonstrating.** **OR**
- Exhibit one framed 8" x 24" or smaller panorama photograph using the skills learned on pages 62-65(section: Panorama) of the project manual titled *Level 2 Next Level Photography*. No photo editing is allowed in this class except cropping and red eye removal. **Be prepared to show the page in the manual of the technique you are demonstrating.**
- Exhibit one framed 8" x 10" photo which demonstrates your understanding of a technique you learned from your Photography 2 project manual. No photo editing is allowed in this class except cropping and red eye removal. Be prepared to show the page in the manual of the technique you are demonstrating.

Photography 3 (SF 50270)

Exhibit one of the options listed below:

- Exhibit one framed 8" x 10" still-life photo that demonstrates good composition, including color, form, texture, lighting and depth of field. No photo editing is allowed in this class except cropping and red eye removal. **Be prepared to show the page in the manual of the technique you are demonstrating.** **OR**
- Exhibit one framed 8" x 10" photo which demonstrates your understanding of a technique you learned from your Photography 3 project manual. No photo editing is allowed in this class except cropping and red eye removal. **Be**

prepared to show the page in the manual of the technique you are demonstrating.

Photo Editing (SF 50271)

Open to members in Photography 1, Photography 2, and Photography 3.

Exhibit one framed 8" x 10" photo that has been altered using digital photo-editing techniques (beyond cropping and red-eye reduction). Include a print of the original photo(s), taped to the back of the photo frame. Photos in which an automatic filter was applied at the time the photograph was taken will not be eligible for award.

Photography Ready4Life Challenge

For Ready4Life Career & Entrepreneurship Exploration exhibit opportunities for this project area, visit the Ready4Life section of this document.

PLANTS & SOILS

Each county may submit 3 entries total from 50280, 50281a, 50281b, 50281c.

Cover Crops (SF 50280)

Exhibit an experimental or educational activity related to one experience from your project; **OR** prepare a display focusing on any activity related to the cover crops project. This could be related, but not limited, to plant growth & development, cover crop benefits, land management, sustainability, or other topics of interest to the member related to cover crops. A cover crop might include any plant that is sown in between primary production crops for the benefit of overall farm health rather than crop yield (examples: pennycress, clover, radish, annual ryegrass, etc.). The exhibit may include, but isn't limited to, original works, objects, demonstrations, digital presentations, programs, websites, games, apps, performances, or posters which you have made. Choose whatever method best shows what you've learned. You must furnish any equipment you need for your exhibit. Internet service will not be provided for the exhibit. All exhibits must include something visual, such as a printed copy of a digital presentation, which will remain on display during the exhibition. Electronic equipment will only be used during your personal judging time and will not remain on display during the entire exhibit period.

Plants & Soils 1 (SF 50281a)

Prepare a 36" X 48" display or a poster no larger than 18" X 24" that illustrates an activity from the project manual. The display should demonstrate an understanding of environmental and internal factors that affect plant growth and the function and characteristics of soil. Include your project journal that documents activity recordkeeping requirements, answers activity questions, and details personal thoughts and ideas in response to each activity.

Plants & Soils 2 (SF 50281b)

Prepare a 36" X 48" display or a poster no larger than 18" X 24" that illustrates an activity from the project manual. The display should demonstrate an understanding of the composition of plants, the functions of individual plant parts, plant life cycles, and the many ways plants reproduce. Include your project journal that documents activity recordkeeping requirements, answers activity questions, and details personal thoughts and ideas in response to each activity.

Plants & Soils 3 (SF 50281c)

Prepare a 36" X 48" display or a poster no larger than 18" X 24" that illustrates an activity from the project manual. The display should demonstrate an understanding of the relationship between soil and other cycles found in nature. Displays should also provide an example of a leadership or service-learning experience focused on environmental stewardship. Include your project journal that documents activity recordkeeping requirements, answers activity questions, and details personal thoughts and ideas in response to each activity.

Plants & Soils Ready4Life Challenge

For Ready4Life Career & Entrepreneurship Exploration exhibit opportunities for this project area, visit the Ready4Life section of this document.

POULTRY

See Animal Science for non-livestock project or LIVESTOCK section for LIVE animal shows.

RABBITS

See Animal Science for non-livestock project or LIVESTOCK section for LIVE animal shows.

READY4LIFE CAREER & ENTREPRENEURSHIP EXPLORATION

Each county may send 2 entries from 50366a and 2 entries from 50366b.

Ready4Life Exploration (Career) (50366a)

Open to 11- to 18-year-olds.

Exhibits in this category must include the following: a) a physical representation of the career such as a model, prototype or display/portfolio that includes images of accomplished work; b) verbal or written explanations that demonstrate knowledge of the related career or business fields, potential careers, and the appropriate requirements for achievement in those fields. The judging criteria for this class values thoroughness of career exploration and pursuit above the workmanship of the physical specimen on display.

Ready4Life Exploration (Entrepreneurship) (50366b)

Open to 11- to 18-year-olds.

Exhibits in this category must include the following: a) a physical representation of the business product such as a model, prototype or display/portfolio that includes images of accomplished work; b) verbal or written explanations that demonstrate knowledge of the related business fields, potential business opportunities, and the appropriate requirements for achievement in those fields. The judging criteria for this class values thoroughness of the business exploration and pursuit above the workmanship of the physical specimen on display.

ROBOTICS

ROBOTICS

Each county may submit 3 entries total from 50285, 50286, 50287, 50288, 50289, 50292.

NOTE: If applicable for their class and display, exhibitors must bring their own computers for demonstration purposes; computers will not be provided. Internet access will not be available.

- Exhibits in classes 50285, or 50286 are designed to be used with LEGO Mindstorms (NXT, EV3, Lego Inventor, Lego Prime).
- Any other programmable robot kit such as Arduino or Raspberry Pi, should be exhibited in Robotics 3 (50292).
- Members should bring their robot to the state fair.

Robotics 1 (SF 50285)

Exhibitors will design, build, and program a robot that uses at least one sensor to autonomously follow a path, respond to and/or avoid obstacles. **The robot must be autonomous and cannot be controlled remotely.** Exhibitors in this class must use at least one sensor in their robot design. Exhibiting youth must complete and display a build log which contains a diagram (drawing or 3D rendering) of their robot with each of the key components labeled, an explanation of why they made the design/programming decisions they made, and a short journal sharing what they learned about the engineering design process and programming throughout their work in the project (as well as while preparing the exhibit). In addition, each youth must bring their program code (on laptop or on paper), and their robot to demonstrate. The robot and obstacles must be able to fit on a 4' x 8' robotics table when being judged, and a 2' x 2' area when being displayed.

Robotics 2 (SF 50286)

Exhibitors will design, build and program a robot that uses sensors and programming to complete one of the selected challenges from the 2024 4-H State Robotics Challenge. **The robot must be autonomous and cannot be controlled remotely.** Eligible challenges will be marked in the Challenge Documents and on the Illinois 4-H Robotics website (<https://4h.extension.illinois.edu/ways-participate/projects/robotics>). Exhibiting youth must complete and display a build log which contains a diagram (drawing or 3D rendering) of their robot with each of the key components labeled, an explanation of why they made the design/programming decisions they made, and a short journal sharing what they learned about the engineering design process and programming throughout their work on the project (as well as while preparing the exhibit). In addition, each youth must bring their program code (on laptop or on paper), and their robot to demonstrate. The robot and obstacles must be able to fit on a 4' x 8' robotics table when being judged, and a 2' x 2' area when being displayed.

Robotics 3 (SF 50292)

Open to youth enrolled in Robotics 3, but may also include youth in Robotics 1 or 2 if the exhibit meets the guidelines.

Exhibit an original robot, either homemade or a kit that does not fall under Robotics 1 or 2 that can complete a task using MULTIPLE sensors. **The robot must be autonomous and cannot be controlled remotely.** If a robot kit is used, then some parts of the robot must be built using other components such as wood, plastic or metal. The robot can include any type of motors, pneumatics or sensors. The Innovation class can also be used for LEGO Mindstorms/ Spike Prime, etc. or Vex kits where the exhibit does not fall under Robotics 1 or 2 exhibit option. Autonomous control of the robot may also be achieved using an "open source" platform such as Arduino or Raspberry Pi and can be programmed using a coding language that is publicly available. Exhibitors in Robotics Innovation/Open-Source class must complete and display a build log which contains a diagram (drawing or 3D rendering) of their robot with each of the key components labeled, an explanation of why they made the design/programming decisions they made, and a short journal sharing what they learned about the engineering design process and programming throughout their work in the project (as well as while preparing the exhibit). In addition, each youth must bring their program code (on laptop or on paper), and their robot to demonstrate. Exhibits in this class must be able to fit on no more than a 6' x 2' table (or ground footprint), and must be fully assembled 15 minutes prior to the judging start time. No Exceptions.

Junk Drawer Robotics

All exhibits should be original designs made with everyday objects and materials. Exhibits with purchased kits will not be accepted. Exhibitors are also required to bring their Junk Drawer Robotics Youth Robotics Notebook with the sections completed for the project they are exhibiting, including the sections leading up to the activity they are exhibiting. For example, if a youth is bringing Activity E from Junk Drawer Level 1, they should have robotics notebook sections A-E completed.

Junk Drawer Robotics 1 (SF 50287)

Exhibit any item from the "To Make" activity from the Junk Drawer Robotics Level 1 Book. Be sure all robotics notebook sections within the module being exhibited are filled in.

Junk Drawer Robotics 2 (SF 50288)

Exhibit any item from the "To Make" activity from the Junk Drawer Robotics Level 2 Book. Be sure all robotics notebook sections within the module being exhibited are filled in.

Junk Drawer Robotics 3 (SF 50289)

Exhibit any item from the "To Make" activity from the Junk Drawer Robotics Level 3 Book. Be sure all robotics notebook sections within the module being exhibited are filled in.

Robotics Ready4Life Challenge

For Ready4Life Career & Entrepreneurship Exploration exhibit opportunities for this project area, visit the Ready4Life section of this document.

SHEEP

See Animal Science for non-livestock project or LIVESTOCK section for LIVE animal shows.

SHOOTING SPORTS

Each county may submit 2 entries total from 50380, 50381, 50382, 50383, 50384.

Participants must be a member of an approved 4-H Shooting Sports Club to exhibit. All exhibits should be posters or stand-alone items suitable for display to the general public. Stand-alone items have the intent to enhance the discipline such as a quiver, gun case, gun sling, locking cabinet, gun or target stand, sporting clays equipment wagon, etc. Exhibits deemed to be inappropriate by a superintendent will not be displayed.

NOTE: Shooting Sports Displays have the following prohibitions:

- No live ammunition.
- No knives or arrow tips (including field points, hunting broadheads, etc.).
- No functional or non-functional bows, firearms or firearm parts that could be reassembled are allowed.
- No humanoid shaped targets or reference to paintball, laser tag, air-soft, or pointing of any type of firearm or bow toward another person is allowed.
- No display involving primarily tactical design firearms (i.e. AR platform or military type firearms).
- No reference or use of the word “weapon” should be used in a display.
- Make sure there are no safety violations in your display. (Example: no earplugs or safety glasses in a picture of a person shooting a firearm.).

Shooting Sports: Archery Display (SF 50380)

Exhibit a poster or stand-alone display depicting safe archery handling, range safety, the parts of the bow, tracking the target, target sighting, or another topic you have learned through the 4-H Shooting Sports program.

Shooting Sports: Rifle Display (SF 50381)

Exhibit a poster or stand-alone display depicting safe firearm handling, range safety, the parts of the rifle, tracking the target, target sighting, or another topic you have learned through the 4-H Shooting Sports program.

Shooting Sports: Shotgun Display (SF 50382)

Exhibit a poster or stand-alone display depicting safe firearm handling, range safety, the parts of the shotgun, tracking the target, target sighting, or another topic you have learned through the 4-H Shooting Sports program.

Shooting Sports: Hunting & Outdoor Skills Display (SF 50383)

Exhibit a poster or stand-alone display related to something you learned in the Hunting & Outdoor Skills project.

Shooting Sports: Pistol Display (SF 50384)

Exhibit a poster or stand-alone display depicting safe firearm handling, range safety, the parts of the pistol, tracking the target, target sighting, or another topic you have learned through the 4-H Shooting Sports program.

Shooting Sports Ready4Life Challenge

For Ready4Life Career & Entrepreneurship Exploration exhibit opportunities for this project area, visit the Ready4Life section of this document.

SMALL ENGINES

Each county may submit 1 entry total for 50294.

Small Engine displays must be no larger than 4' x 4' display board. Exhibits must be portable. No complete engines, lawn tractors, tillers, chainsaws, etc. are permitted for display. No electrical power is available for displays/exhibits.

Small Engines 1-3 (SF 50294)

- Exhibit a display, selecting one of the following items:
- **Ignition/Electrical System:** Identify the parts of the Ignition System and explain how magnetic energy is produced through the ignition system to ignite the spark plug; **OR**
- **Compression System:** Explain how heat energy is produced and engine power is measured by an engine and/or converted into mechanical energy through transmissions; **OR**
- **Heat Transfer:** Explain how heat is transferred through the cooling and lubrication system of an air cooled or water cooled engine; **OR**
- **Filter Maintenance:** Explain the proper maintenance and cleaning of the air, fuel and oil filters of an engine; **OR**
- **What does a serial number reveal?:** Explain the various information that can be learned from the serial number or identification number stamped on the shroud of a Briggs & Stratton engine; **OR**
- **Tools to do the job:** Identify and explain the function(s) of different specialty tools needed for small engine work, **OR**
- **Experimentation:** Explain through illustration an experiment you conducted from the project manual showing the results of your work.

Small Engines Ready4Life Challenge

For Ready4Life Career & Entrepreneurship Exploration exhibit opportunities for this project area, visit the Ready4Life section of this document.

SMALL PETS

For youth enrolled in Small Pets 1, Small Pets 2, Small Pets 3. All Small Pet projects will be in Animal Science at the state level.

Each county may submit 2 entries total from 50135a and 50135b.

Small Pets will be shown at the General Project Show, please contact the Extension Office to make animal arrangements.

Animal Science Small Pets (SF 50135)

Prepare a display focusing on any activity related to the small pets project. Demonstrate the skills and knowledge you have gained through the animal project you studied. The exhibit may include, but isn't limited to, original works, objects, demonstrations, digital presentations, programs, websites, games, apps, performances, or posters which you have made. Choose whatever method best shows what you've learned. You must furnish any equipment you need for your exhibit. Internet service will not be provided for the exhibit. All exhibits must include something visual, such as a printed copy of a digital presentation, which will remain on display during the exhibition. Electronic equipment will only be used during your personal judging time and will not remain on display during the entire exhibit period. Live animals are not permitted as exhibits in this area. For safety reasons, exhibits cannot include glass, syringes with needles or any other sharp objects.

Animal Science Guinea Pigs Display (SF 50135)

Prepare a display focusing on any activity related to the guinea pigs project. Demonstrate the skills and knowledge you have gained through the animal project you studied. The exhibit may include, but isn't limited to, original works, objects,

demonstrations, digital presentations, programs, websites, games, apps, performances, or posters which you have made. Choose whatever method best shows what you've learned. You must furnish any equipment you need for your exhibit. Internet service will not be provided for the exhibit. All exhibits must include something visual, such as a printed copy of a digital presentation, which will remain on display during the exhibition. Electronic equipment will only be used during your personal judging time and will not remain on display during the entire exhibit period. Live animals are not permitted as exhibits in this area. For safety reasons, exhibits cannot include glass, syringes with needles or any other sharp objects.

THEATRE ARTS

Each county may submit 3 entries total for 50299, 50300, 50301, 50302.

Theatre Arts 1 (SF 50299)

Exhibit one of the following items:

- **Portfolio of acting activities** completed during the current year. This should include at least 3 of the following: list of roles/performances, pictures or description of hair or makeup, pictures or description of a favorite costume, pictures or description of a particular set piece or prop, ticket stubs or marketing materials, playbill, description of audition process, highlights of acting skills honed (such as stage directions, auditioning, projection, diction, character development, physicality, vocal expression, facial expressions, memorization, understanding of how to read a script, ability to take direction, confidence, collaboration with scene partners etc.) *Note: A video of performances is not considered a portfolio and will not be accepted for exhibit.* **OR**
- **Display illustrating a picture story** developed by the exhibitor. Your picture story should include a minimum of 3 boxes with a character, problem, and solution. **OR**
- **Write a personal monologue.** Create a character, decide what your character wants, what are the obstacles, and create your character's thoughts and struggles.

Theatre Arts 2 (SF 50230)

Exhibit one of the following items:

- **Block a scene.** Choose a scene from a published play and become the director. Clearly mark stage directions, blocking, entrances and exits, and any additional notes you would want to share with the actors. **OR**
- **Write a scene.** Create a scene that includes at least 2 characters, has an established setting, plot, and time, and include stage directions. **OR**
- **Create a mask** that either represents a character of your choice or models a mask from a given historical time period integral to the history of theatre.

Theatre Arts 3 (SF 50301)

Exhibit one of the following items:

- **Portfolio of activities** for set design; make-up; or sound, props, or costuming completed during the current year. This should include pictures of activities, information on the show or performance, details on your involvement. **OR**
- **Display that includes** sound, props and costume charts appropriate for a selected scene from a story or play (limited to no more than 8 items). **OR**
- **Display a scenic design model** to depict a scene from a script; **OR**
- **Display illustrating a character** with make-up drawn or colored in. Include a photograph of a person wearing the make-up and information on the character's personality or part in the play.
-

Theatre Arts Innovation Class (SF 50302)

Open to youth enrolled in Theatre Arts.

Demonstrate the skills and knowledge you have gained through Theatre Arts project. The exhibit may include, but isn't limited to, original works, objects, demonstrations, digital presentations, programs, websites, games, apps, performances, or posters which you have made. Choose whatever method best shows what you've learned. Your exhibit should not fit in the other exhibit options for this project. You must furnish any equipment you need for your exhibit. Internet service will not be provided for the exhibit. All exhibits must include something visual, such as a printed copy of a digital presentation, which will remain on display during the exhibition. Electronic equipment will only be used during your personal judging time and will not remain on display during the entire exhibit period.

Theatre Arts Ready4Life Challenge

For Ready4Life Career & Entrepreneurship Exploration exhibit opportunities for this project area, visit the Ready4Life section of this document.

TRACTOR

Each county may submit 2 entries total for 50306, 50307, 50308, 50309, 50310.

Tractor A (SF 50306)

Exhibit a display or poster that illustrates one of the following topics: tractor safety; care and maintenance; the tractor as a valuable farm machine; or an activity listed in the 4-H project manual.

Tractor B (SF 50307)

Exhibit a display or poster that illustrates one of the following topics: cause and prevention of rollovers; diagram how an air cleaner works; diagram and identify an engine cooling system; regulations for battery & oil disposal; or another activity listed in the 4-H project manual.

Tractor C (SF 50308)

Exhibit a display or poster that illustrates one of the following topics: wagon and bin hazards; diagram and identify open and closed hydraulic systems; mower types and safety features; conveyor types and safety features; or another activity listed in the 4-H project manual.

Tractor D (SF 50309)

Exhibit a display or poster that illustrates one of the following topics: method of winterizing a tractor; chemical uses and required safety equipment; parts and process of internal combustion engine; procedure for cleaning and flushing tractor radiator; or another activity.

Tractor Innovation Class (SF 50310)

Open to youth enrolled in Tractor A, B, C or D.

Demonstrate the skills and knowledge you have gained through the Tractor project. This could be related to, but not limited to, advancements in technology, enhancements to crop production, or a topic of interest to the member related to tractors or farm machinery. The exhibit may include, but isn't limited to, original works, objects, demonstrations, digital presentations, programs, websites, games, apps, performances, or posters which you have made. Choose whatever method best shows what you've learned. Your exhibit should not fit in the other exhibit options for this project. You must furnish any equipment you need for your exhibit. Internet service will not be provided for the exhibit. All exhibits must include something visual, such as a printed copy of a digital presentation, which will remain on display during the exhibition. Electronic equipment will only be used during your personal judging time and will not remain on display during the entire exhibit period.

Tractor Ready4Life Challenge

For Ready4Life Career & Entrepreneurship Exploration exhibit opportunities for this project area, visit the Ready4Life section of this document.

VETERINARY SCIENCE

Each county may submit 1 entry total from 50320.

Veterinary Science (SF 50320)

Open to youth in Veterinary Science A, Veterinary Science B, and Veterinary Science C

Prepare a display focusing on any activity related to the veterinary science project. The exhibit may include, but isn't limited to, original works, objects, demonstrations, digital presentations, programs, websites, games, apps, performances, or posters which you have made. Choose whatever method best shows what you've learned. You must furnish any equipment you need for your exhibit. Internet service will not be provided for the exhibit. All exhibits must include something visual, such as a printed copy of a digital presentation, which will remain on display during the exhibition. Electronic equipment will only be used during your personal judging time and will not remain on display during the entire exhibit period. Live animals are not permitted as exhibits in this area. For safety reasons, exhibits cannot include glass, syringes with needles or any other sharp objects. Exhibits may include activities from Veterinary Science projects OR from any other Animal project area.

Veterinary Science Ready4Life Challenge

For Ready4Life Career & Entrepreneurship Exploration exhibit opportunities for this project area, visit the Ready4Life section of this document.

VIDEO

Each county may submit 3 entries total from 50324, 50325, 50326, 50327, 50328. Enrollment in the Video project is required to exhibit in the classes in this section.

All Exhibitors must bring their video to be judged on a USB flash drive and saved in .MP4 format. Exhibitors are encouraged to post their video on YouTube.com in advance of State Fair. Exhibitors may choose whether to make the video "public, unlisted" (someone must have the link to view it), or "private" (only people you choose may view it). This will allow fairgoers to view the exhibits on display. There will be monitors at the exhibit table for viewing videos so exhibitors will NOT need to bring a laptop or device for viewing.

Requirements that apply to ALL video classes:

Video submissions should be no longer than five (5) minutes in length (unless noted differently in class description). Videos are to be original and a result of the member's current year's work. Criteria for judging shall include: (1) Evidence of story line; (2) Use of camera angles; (3) Use of zooming techniques; and (4) Smoothness of scene changes. Image and sound quality will be considered in relation to equipment available to and used by exhibitor. All videos should comply with copyright regulations and display an image that is appropriate for 4-H audiences. No time or date should be imprinted on the video footage. All videos should include an opening title screen, as well as closing credits which include date of production, name of video exhibitor and research sources if appropriate. **All Video/Filmmaking exhibitors must include a printed copy of materials which will remain on display.**

Commercial or Promotional Video (SF 50324)

Prepare a short video (30 seconds to 1 minute in length) that promotes an event, advertises a specific project/product, or is a public service announcement. The video should demonstrate skills in making and editing video.

Animated Video (SF 50325)

Video in this class should represent creative animation of original artwork created by the exhibitor and may include stop motion techniques. Media might include images created with graphics software or hand-drawn images.

Documentary (SF 50326)

Video in this class should represent a research-based investigation into a topic of choice. Video credits should list research sources and may include paper or electronically published materials, as well as interviews with experts or constituents related to the topic of investigation.

Short Story or Short Narrative (SF 50327)

Prepare a short video that tells a story. The video should demonstrate skills in making and editing video.

Video/Filmmaking Innovation Class (SF 50328)

Open to youth enrolled in Video/Filmmaking

Demonstrate the skills and knowledge you have gained through the Video project. **Your exhibit should not fit in the other exhibit options for this project.** The exhibit may include, but isn't limited to, original works, objects, demonstrations, digital presentations, programs, websites, games, apps, performances, or posters which you have made. Choose whatever method best shows what you've learned. You must furnish any equipment you need for your exhibit. Internet service will not be provided for the exhibit. All exhibits must include something visual, such as a printed copy of a digital presentation, which will remain on display during the exhibition. Electronic equipment will only be used during your personal judging time and will not remain on display during the entire exhibit period.

Video/Film Ready4Life Challenge

For Ready4Life Career & Entrepreneurship Exploration exhibit opportunities for this project area, visit the Ready4Life section of this document.

VISUAL ARTS

Each county may submit ONE entry from each of these projects:

- Chalk/Carbon/Pigment on wood, metal or textiles (Division B) 50352
- Clay 50337
- Computer-Generated Art 50338
- Fiber 50339
- Fiber Non-Original Ages 8-10 Only 50350
- Heritage Arts 50341
- Leather 50321
- Metal 50342
- Nature 50343
- Paper 50344A
- Paper 50344B
- Quilting – You Can Quilt 50331A
- Quilting – Quilting the Best Better 50331B
- Three-Dimensional Design/Mixed Media 50348
- Wood 50349

Each county may submit TWO entries from:

- Chalk/Carbon/Pigment on canvas, paper or glass (Division A) 50336
- Food Decorating (2 total from 50332, 50333, 50334, 50335)
- Glass & Plastic (2 total from 50340a, 50340b, 50340c)
- Scrapbooking (2 total from 50345, 50346, 50347)

Exhibitors must be enrolled in the Visual Arts project category in which they are exhibiting. Exhibitors are encouraged to date the project when it is made. Exhibitors must be able to carry or cart their exhibits across the fairgrounds from the parking lots. All visual arts exhibits are evaluated using a visual arts rubric which takes into account correct use of design elements; craftsmanship; and creativity.

Articles exhibited must be an original design created by the exhibitor (except in Heritage Arts, which may follow a pattern, AND Fiber-Non-Original Ages 8-10 ONLY). Copyrighted or trademarked designs are not acceptable; this includes team,

school logos and/or characters from movies such as Mickey Mouse, Iron Man, etc. Kits and preformed molds are not considered original and are not acceptable in any Visual Arts Class. Combining parts of different patterns (pictures, photographs, images from the internet or a magazine) with the member's own ideas can result in an original design, but simply changing the color, pattern and/or size of a pattern does NOT make the design original. This also applies for ideas found on a site such as Pinterest. **If you see something on Pinterest that you like, you can use that idea as your inspiration, however, create something which is fundamentally different. It MUST NOT BE AN EXACT REPLICA OF something the judge can search for and find on Pinterest.** The exhibit may combine parts of different patterns and/or ideas with the concepts of the member, however changing the color or changing the size of the item or pattern used does NOT make it original. If you create an exact replica of what you see somewhere else, it is not your original design. If a photo, sketch, or other idea source was used, submit it with your entry, firmly attached to your exhibit. Be prepared to explain how and where you got the idea for this project.

Copyrighted or trademarked designs are not acceptable; this includes team logos, school logos, and/or characters from movies such as Mickey Mouse, Iron Man, etc. Kits and packaged plastic block sets are not considered original and not acceptable in any Visual Arts Class.

Use of the 4-H Clover: Chartered 4-H clubs and enrolled 4-H members are authorized to use the 4-H Name and Emblem. This includes permission for an enrolled 4-H member to use the 4-H name and emblem in exhibits created for personal use and as part of 4-H sponsored events. This includes 4-H decorated cookies, a 4-H clover printed for use in a scrapbook or included as part of any other 4-H exhibit. Use of the green clover shaped image is not protected. The 4-H "emblem" is distinguished by the four H's that signify Head, Heart, Hands and Health. **No creative rendering, changes in color or shape of the official 4-H emblem is allowed.**

NOTE – Any use of the 4-H name and emblem on items intended as **gifts or for sale locally** requires prior permission from your local Extension office. Your Extension office will be able to provide you with the form which must be signed by the Extension County Director. Any uses of the 4-H name and emblem for sale or promotion **online, and/or in statewide events** should be signed by the Illinois 4-H Program Leader (Illinois4H@illinois.edu).

Quilts entered in Visual Arts should **ONLY** be entered in the Quilting Project area in either Level 1 *You Can Quilt* (SF 50331A) OR Level 2 *Quilting the Best Better* (SF 50331B). All work on the quilt **MUST** be completed by the 4-H member. You cannot exhibit a quilt that was quilted by someone else.

Read Visual Arts exhibit guidelines thoroughly. Some exhibit categories have size restrictions!

Visual Arts Food Decorating Beginning (SF 50332)

Exhibit one of the following:

- Exhibit four decorated cookies, using a minimum of four different Level 1 techniques. Exhibit may use cookies OR cookie forms.
- Exhibit four decorated cupcakes, using a minimum of four different Level 1 techniques. Exhibit may use cupcakes OR cupcake forms.
- Exhibit a single layer decorated cake, using a minimum of four different Level 1 techniques. Exhibit may use cake OR cake form.

Visual Arts Food Decorating Intermediate (SF 50333)

Exhibit one of the following:

- Exhibit four decorated cookies, using a minimum of five Level 2 techniques. Exhibit may use cookies OR cookie forms
- Exhibit four decorated cupcakes, using a minimum of five Level 2 techniques. Exhibit may use cupcakes OR cupcake forms.

- Exhibit a single layer or two-layer cakes, using a minimum of five Level 2 techniques. Exhibit may use cake OR cake forms.

Visual Arts Food Decorating Advanced (SF 50334)

- Exhibit a decorated, stacked or multi-layer cake; or a tiered cake, using a minimum of four Level 3 techniques. Exhibit may use cake OR cake forms.

Visual Arts Food Decorating Master (SF 50335)

Exhibit an original design decorated cake using more than five techniques. Exhibit may use cake OR cake forms. In addition, include a one-page written description of your project, including goals, plans, accomplishments, and evaluation of results. Up to four pictures of your accomplishments may be included in the description.

Visual Arts Chalk/Carbon/Pigment: Division A & B

Enter the division based on the type of material on which the art was created.

Chalk/Carbon/Pigment: Division A: Canvas, Paper, Glass (SF 50336)

Any original artwork created with pencils, chalk, pens, ink, paint, charcoal, dyes, etc. on canvas, paper, or glass. This would include all painting, sketching, drawing, cartooning, original non-computer-generated graphics, printing, etc. Painted and/or glazed pre-formed ceramics and painted porcelain dolls are not eligible for the State Fair exhibit. Drawings and paintings should be matted or framed under glass. (Exceptions: Oil and acrylic paintings do not require glass and are not required to be matted.) Watercolor, chalk, pen & ink, computer-generated art, etc. do require some protective covering. Gallery frames are acceptable. Canvas paintings that continue “over the edges” are acceptable without frames; however, the piece must still be prepared for hanging. Matted pieces without frames are acceptable, however the piece must be prepared for hanging OR it must include a photo of the artwork being displayed in a non-hanging manner. There is no specific requirement for the type of mat used.

Chalk/Carbon/Pigment: Division B: Wood, Metal, Textiles (SF 50352)

Any original artwork done with pencils, chalk, pens, ink, paint, charcoal, dyes, etc., on wood, metal, or textiles. Painted and/or glazed pre-formed ceramics and painted porcelain dolls are not eligible for State Fair exhibit. Any exhibits created as a piece of wall art must be prepared for hanging.

Visual Arts Clay (SF 50337)

Any original item made of clay; may be fired or unfired, hand formed or thrown on a wheel. Self-hardening clays are fine. Fire/oven-cured and cornstarch clay could be accepted. Items can include, but are not limited to, clay statues, bowls, jewelry, etc. Pre-formed ceramics are not eligible for State Fair exhibit.

Visual Arts Computer-Generated Art (SF 50338)

Any original art created in any software package. Exhibit may not include scanned work, clip art, downloaded images from the internet, any imported image, or photographs. All pixels must be original. Photo mosaics are NOT allowed. Exhibitors in this class (like all other classes in this sub-section) must be enrolled in Visual Arts; Computer project enrollment is not required. NOTE: Wood and metal exhibits created through the use of laser cutting programs/devices should be entered in this class. Plastic exhibits with an artistic focus created using a 3-D printer should be entered in this class. If the art created is designed to hang, then the entry should have some protective covering, such as a glass frame, and prepared for hanging. If the art is something that has been created with a laser cutting program/device and is NOT designed to hang, it does not require protective covering nor does it need to be prepared to hang.

Visual Arts Fiber (SF 50339)

Any original item made of fiber. Examples include but are not limited to fabric collage, soft sculpture, stitchery, weaving, embroidery, cross-stitch, wearable art, hooking, braiding, duct tape artistry, string art, and baskets. **Original** cross-stitched, knitted, or crocheted items belong in this Fiber class. **Non-original** cross-stitched, knitted, or crocheted items should be entered in Heritage Arts. Machine knitted items are not appropriate for this class.

Visual Arts Fiber Non-Original AGES 8-10 ONLY (SF 50350)

Any non-original item made of fiber. Examples include but are not limited to fabric collage, soft sculpture, stitchery, weaving, embroidery, cross-stitch, crocheting, knitting, weaving, hooking, and felting. Exhibitors may use a pattern and/or an idea generated from another source.

Visual Arts Glass & Plastic (SF 50340A, 50340B, 50340C)

Any original item made of glass or plastic.

- **50340A – Glass** - Possible items to exhibit include stained glass, etched glass (original design), mosaics made of glass, glass beading.
- **50340B – Plastic** - Possible items to exhibit include plastic jewelry (friendly plastic); recycled plastic art; plastic that can be molded into 3D shapes.
- **50340C – Plastic Block Art** - Any original item made entirely of plastic building blocks. This must be an **original design created by the exhibitor**. Structures are NOT eligible in the Visual Arts Plastic Block Art exhibit area. The exhibit will be judged using a Visual Arts rubric. The exhibit must be attached to a board or frame for display and prepared to be hung or presented as 3-dimensional piece of table art, however NOT a structure (unacceptable items would include buildings, rollercoasters, etc.).

Interlocking building block creations (i.e. LEGOS) are ONLY suitable for 50340C exhibit option of the Visual Arts Glass & Plastic class. Steppingstones can be entered as a Visual Arts exhibit in Glass & Plastic; however they must have an intentional design created using glass and/or plastic and the exhibitor must be prepared to discuss the design elements associated with their exhibit. Due to space limitations, any single exhibit in the Glass & Plastic project should NOT exceed 48" x 48".

Visual Arts Heritage Arts (SF 50341) Exhibit an item of **traditional** art learned from another person or **from a pattern** (NO KITS may be entered in this class). Non-original cross-stitched, knitted and crocheted items by pattern fit in this class. ALL ORIGINAL cross-stitched, knitted and crocheted items should be exhibited in Fiber Arts; (machine knitted items ARE NOT acceptable for this class.) Other possibilities include: needlepoint, counted cross-stitch, crewel, embroidery, cut work, hardanger embroidery (embroidery openwork), macramé, candles, blacksmithing, pysanki (decorated eggs), baskets (made using a traditional pattern), traditional handmade dolls with handmade costumes, soaps made using nature dyes and/or candles.

Exhibitors in Heritage Arts MUST also bring 1) the pattern or a copy of the pattern they used to create their traditional art; and 2) be prepared to explain the traditional origins of their art choice.

Visual Arts Leather (SF 50321)

Exhibit one of the following options using leather:

- **Leather Stamping:** Exhibit should utilize one or more stamping techniques – exhibit examples include items such as belt; coasters; bookmark; key chain; wrist bracelet.
- **Leather Carving or Tooling:** Exhibit should use simple swivel knife tooling techniques or may incorporate several swivel knife-tooling designs or patterns – exhibit examples include items such as belt; pictorial carving; key case.
- **Leather Lacing:** Exhibit to include stamping and/or carving techniques incorporated with lacing techniques – exhibit examples include items such as wallets; purses; etc.
- **Leather Stitching:** Exhibit may include stamping, carving and/or lacing techniques and should be a leather item or article of apparel, which incorporates hand-sewing and/or machine stitching techniques. Hand-sewing and/or machine stitching must be the work of the exhibitor.

Visual Arts Metal (SF 50342)

Any original item made of metal such as sculpture, tin punch, engraved metal, and jewelry. Items intended for industrial use (such as tools and/or shop items) are not considered part of this Visual Arts project and are not eligible for entry. Metal items that have been partially or totally created through the use of laser cutting programs/devices should be entered in Computer-Generated Art.

Visual Arts Nature (SF 50343)

Any original item made of natural material such as wreaths, cornhusk dolls, etc. Items should be made of natural materials (which may be purchased) but securing elements such as glue and wire may be used in the inner construction as long as they do not detract from the overall "natural" appearance. **Articles such as dried pressed flowers may be displayed under glass if viewed as necessary for protection/preservation of the natural materials.** Candles are not suitable as entries and instead should be entered in Heritage Arts. All baskets should be entered in Heritage Arts.

Visual Arts Paper (SF 50344a & SF 50344b)

Any original item made of paper. Exhibitors should create an exhibit that aligns with one of the following categories:

- **50344a** Two-Dimensional Paper Art – Exhibits should be a 2-dimensional image. Paper art which falls into the 2-dimensional category includes: Greeting Cards; paper-cut designs; hand-made paper; paper collage; quilling.
- **50344b** Three-Dimensional Paper Art – Exhibits should be a 3-dimensional image. Exhibits in the 3-dimensional category must have multiple layers and/or levels. This is defined as more than 3 layers so the image truly has dimensions that can be viewed from at least three sides; or is at least ½" tall. Paper art which falls into the 3-dimensional category includes but is not limited to: Origami; Paper Mache; Paper models of architecture, paper-cut designs; quilling.

PLEASE NOTE THE FOLLOWING:

1. Paper-cut designs and quilling have the potential, depending on the design, to align with either of the categories. The key design element is whether the design is 2-dimensional or 3-dimensional.
2. Paper twist articles made from a kit or directions in a craft book or store ARE NOT original and not appropriate in the Visual Arts Paper exhibit area. Scrapbooks are also not eligible in Visual Arts Paper but should be exhibited in Visual Arts Scrapbooking.

Visual Arts Quilting – You Can Quilt (Level 1) (SF 50331a)

Exhibit one of the following quilting options. All exhibits should include a card which 1) Identifies the item as an original design created by the exhibitor; as a pattern created by someone else; OR as a pattern that has been adapted by the exhibitor. AND 2) Identifies the type of batting used. The item may be quilted using any method – tie, hand, or machine quilted. **All work must be completed by the 4-H member.** Exhibit one of the following:

- A Doll Quilt (maximum size of 24" x 30"); OR
- A Baby Quilt (*maximum size of 48"x48"*); OR
- A Quilted Table Runner (maximum size of 18" x 36"); OR
- A small Wall Hanging (square or rectangular (maximum size of 36" x 36")). Hanging should include tabs or a pocket on the back for it to be hung.

Visual Arts Quilting – Quilting the Best Better (Level 2) (SF 50331b)

Exhibit one of the following quilting options. All exhibits should include a card which 1) Identifies the item as an original design created by the exhibitor as a pattern created by someone else; OR as a pattern that has been adapted by the exhibitor; 2) Identifies the type of batting used; AND 3) Provides details on any special techniques that were used (applique, embroidery, free-motion quilting, etc.). The item may be quilted using any method – tie, hand, or machine quilted. **All work must be completed by the 4-H member.** Exhibit one of the following:

- A Lap Quilt (*width ranging from 42" – 58" length ranging from 56" – 70"*): OR
- A Large Quilted Wall Hanging (*can be rectangular or square, sized larger than 36" x 36"*). Hanging should include tabs or a pocket on the back for it to be hung; OR
- A Quilt that fits any size bed (Twin, Double, Queen or King).

Visual Arts Scrapbooking, Beginning (SF 50345)

Exhibit one album or notebook, either 8 ½" x 11" or 12" x 12", with a front and back cover. The album/notebook must have

a minimum of 4 pages (front and back, making it 8 sides), exhibited in page protectors. **NOTE – the front and back album covers are NOT part of the “page” count.** “Embellishments” are defined as the decorations or special details and features that add to a page and make it more visually appealing. Embellishments may include, but are not limited to, ribbon, clips, stickers, special lettering, etc. Beginners must use a **minimum of four embellishments** in their 4 scrapbook pages (a **minimum of four embellishments on the 4 required scrapbook pages, not four per page**), 8 sides and tell a story with pictures

Visual Arts Scrapbooking, Intermediate (SF 50346)

Exhibit one album or notebook, either 8 ½” x 11” or 12” x 12”, with a front and back cover. The album/notebook must have a minimum of 6 pages (front and back, 12 sides), exhibited in page protectors. **NOTE – the front and back album covers are NOT part of the “page” count.** “Embellishments” are defined as the decorations or special details and features that add to a page and make it more visually appealing. Embellishments may include, but are not limited to, ribbon, clips, stickers, special lettering, etc. Intermediate level exhibitors must use a **minimum of eight embellishments** in their 6 scrapbook pages (a **minimum of eight embellishments on the 6 required scrapbook pages, not eight per page**), 12 sides and tell a story with pictures and journaling.

Visual Arts Scrapbooking, Advanced (SF 50347)

Exhibit one album or notebook, either 8 ½” x 11” or 12” x 12”, with a front and back cover. The album/notebook must have a minimum of 8 pages (front and back, 16 sides), exhibited in page protectors. **NOTE – the front and back album covers are NOT part of the “page” count.** “Embellishments” are defined as the decorations or special details and features that add to a page and make it more visually appealing. Embellishments may include, but are not limited to, ribbon, clips, stickers, special lettering, etc. Advanced level exhibitors must use a **minimum of 12 embellishments** in their 8 scrapbook pages (a **minimum of twelve embellishments on the 8 required scrapbook pages, not twelve per page**), 16 sides and tell a compelling story with pictures, journaling, and other media.

Visual Arts Three-Dimensional Design/Mixed Media (SF 50348)

Art pieces in this class must be comprised of **at least three different media**. No one medium can make up more than 40% of a piece. The piece should **be either freestanding or should be prepared to be hung**. It must be observable on at least three different sides. Originality and design are important concepts. Craft and preformed or assembled projects are not acceptable. Due to space limitations, any single exhibit in the Three-Dimensional Design/Mixed Media project should NOT exceed **48” x 48”**.

Visual Arts Wood (SF 50349)

Any original item made of wood (wood carving, sculpture, collage, wood burning, etc.). Utilitarian wood items made from patterns or kits (outdoor or indoor furniture, shelves, etc.) should be entered in woodworking, **NOT** Visual Arts. Popsicle stick crafts are not acceptable for State Fair entry. Wood items that have been partially or totally created through the use of laser cutting programs/devices should be entered in Computer-Generated Art. All Visual Arts Wood exhibits **MUST** have an artistic element that the exhibitor can explain. Furniture built by the exhibitor aligns with the Woodworking project area – unless the element to be judged is wood carving or wood burning that is one element of the exhibit. Exhibits will be judged using a Visual Arts Rubric and not a woodworking construction rubric.

Visual Arts Ready4Life Challenge

For Ready4Life Career & Entrepreneurship Exploration exhibit opportunities for this project area, visit the Ready4Life section of this document.

WEATHER

Each county may submit 1 entry total 50392, 50393, 50394.

Weather and Climate Science 1 (SF 50392)

Exhibit any product or display illustrating an activity from the book. The exhibit may include, but isn’t limited to, original

works, objects, demonstrations, digital presentations, programs, websites, games, apps, performances, or posters which you have made. Choose whatever method best shows what you've learned. You must furnish any equipment you need for your exhibit. Internet service will not be provided for the exhibit. All exhibits must include something visual, such as a printed copy of a digital presentation, which will remain on display during the exhibition. Electronic equipment will only be used during your personal judging time and will not remain on display during the entire exhibit period.

Weather and Climate Science 2 (SF 50393)

Exhibit any product or display illustrating an activity from the book. The exhibit may include, but isn't limited to, original works, objects, demonstrations, digital presentations, programs, websites, games, apps, performances, or posters which you have made. Choose whatever method best shows what you've learned. You must furnish any equipment you need for your exhibit. Internet service will not be provided for the exhibit. All exhibits must include something visual, such as a printed copy of a digital presentation, which will remain on display during the exhibition. Electronic equipment will only be used during your personal judging time and will not remain on display during the entire exhibit period.

Weather and Climate Science 3 (SF 50394)

Exhibit any product or display illustrating an activity from the book. The exhibit may include, but isn't limited to, original works, objects, demonstrations, digital presentations, programs, websites, games, apps, performances, or posters which you have made. Choose whatever method best shows what you've learned. You must furnish any equipment you need for your exhibit. Internet service will not be provided for the exhibit. All exhibits must include something visual, such as a printed copy of a digital presentation, which will remain on display during the exhibition. Electronic equipment will only be used during your personal judging time and will not remain on display during the entire exhibit period.

Weather Ready4Life Challenge

For Ready4Life Career & Entrepreneurship Exploration exhibit opportunities for this project area, visit the Ready4Life section of this document.

WELDING

Each county may submit 2 entries total from 50353.

Welding (SF 50353)

This exhibit class is open to members who are in the 7th grade and higher or at least 12 years 4-H age. Exhibit one arc weldment/item demonstrating the skill level of the exhibitor. Members new to the project should consider selecting a weldment from the suggested *Weldment List* found on page 43 of *Arcs and Sparks* (4-H 573 – Shielded Metal Arc Welding). **This class is for industrial welding only.** (Members that wish to use welding to create objects with an artistic appeal should consider enrolling in the 4-H Visual Arts Metal project and consider entering those types of exhibits in the Visual Arts – Metal class.) Exhibits must be portable and cannot be exhibited on a trailer.

Welding Ready4Life Challenge

For Ready4Life Career & Entrepreneurship Exploration exhibit opportunities for this project area, visit the Ready4Life section of this document.

WOODWORKING

Each county may submit 2 entries total from 50357, 50358, 50359, 50360.

Units 1, 2, and 3 in Woodworking have very specific restrictions on the tools used in building an item to display. This is done for reasons of safety and to provide a fair comparison among projects in a level. **Articles made with tools other than those listed in a level will not be eligible for class awards in that level.**

Woodworking 1 (SF 50357)

Any item made of wood constructed or refinished by the member, appropriate for their age, skills and ability in this project. Pre-cut kits assembled by the member are not acceptable. Exhibits must be portable and cannot be exhibited on a trailer.

Allowed tools in this level: hand tools only, including a hand miter box.

Woodworking 2 (SF 50358)

Any item made of wood constructed or refinished by the member, appropriate for their age, skills and ability in this project. Pre-cut kits assembled by the member are not acceptable. Exhibits must be portable, and cannot be exhibited on a trailer.

Allowed tools in this level: hand tools, power hand drill, miter box (non-powered), oscillating (pad) sander and jigsaw.

Woodworking 3 (SF 50359)

Any item made of wood constructed or refinished by the member, appropriate for their age, skills and ability in this project. Pre-cut kits assembled by the member are not acceptable. Exhibits must be portable, and cannot be exhibited on a trailer.

Allowed tools in this level: hand tools, power hand drill, miter box, jigsaw, scroll saw, power sanders, table saw, drill press, band saw, rabbet plane, jointer, and router.

Woodworking 4 (SF 50360)

Any item made of wood constructed or refinished by the member, appropriate for their age, skills and ability in this project. Pre-cut kits assembled by the member are not acceptable. Exhibits must be portable, and cannot be exhibited on a trailer.

Allowed tools in this level: all those mentioned in levels 1- 3, plus circular saw, radial arm saw, planer, wood lathe, chop saw, and other power tools needed to complete advanced projects.

Woodworking Ready4Life Challenge

For Ready4Life Career & Entrepreneurship Exploration exhibit opportunities for this project area, visit the Ready4Life section of this document.

CLOVERBUDS

INDIVIDUAL PROJECT SHOW & TELL

Non-Premium Eligible Project

Regulations

1. The following class is for youth enrolled as a Cloverbud between the ages of 5-7 years old.
2. Cloverbuds is a non-premium class. Cloverbud participation ribbons will be awarded to each member.
3. All exhibitors must comply with the Fayette County 4-H Show regulations as stated in the front of the 4-H Handbook section.
4. Individual "Show and Share" will be done one-on-one between the 4-H members and judge. An area will be provided for parents to wait or watch inside the judging area.
5. Cloverbuds will show their project during their clubs assigned window, as referenced on page [].

Cloverbud Individual Display

Cloverbud members may exhibit any activity done as a Cloverbud this year.

Project Areas (but not limited to)

- Aerospace 1
- Beading
- Bicycle 1
- Cloverbud Series 1/Cloverbud Activity Book
- Collections
- Embryology 1
- Exploring Farm Animals
- Expressive Arts
- Latino Cultural Arts
- Little Roots
- Personal Development & Leadership
- Science & Technology
- Step Up to Leadership 1
- Vegetable Gardening A
- Veterinary Science 1
- Welcome to 4-H



4-H Livestock Project and Exhibit Rules

The following rules will help you have a successful 4-H Show. Please read these general rules as well as the rules for your animal species. County livestock policies are subject to change at the discretion of the Livestock Committee. Call the Extension office or livestock superintendent if you have any questions or concerns.

GENERAL LIVESTOCK OWNERSHIP AND EXHIBIT RULES

1. All 4-H Show livestock entries are due to the Extension Office at the same time as other general project 4-H Show entries. The entries are due **June 1, 2024**, and submitted online at fairentry.com.
2. 4-H youth who are exhibiting rabbits, chickens, horses, dogs, or cats must complete the online Quality Assurance and Ethics Certification (QAEC) provided by the Illinois 4-H office. The certification has been developed to review what is expected of youth caring for animals. A 4-H member needs only complete the certification one time during their 4-H career. A 4-H member who has already taken the certification and is already on file at the Extension office does not need to re-take the certification. A 4-H member is only required to take the certification in one of the species, regardless of how many animal projects in which they are enrolled. The QAEC training can now be accessed in the Clover Academy section on ZSuite: 4h.zsuite.org. Directions for completing the course can be found at: go.illinois.edu/TakeQAEC. **The certification must be completed by July 1, 2024.**
3. Youth for the Quality Care of Animals (YQCA) is a national multi-species quality assurance program for youth ages 8 to 21. YQCA is currently required for all 4-H exhibitors showing Beef, Goat, Sheep & Swine. All 4-H exhibitors of these animals will be required to certify in the YQCA program yearly. Youth must either attend a face-to-face class or certify online via the website: yqcaprogram.org. Instructions on how to create your account can be found here: go.illinois.edu/YQCAInstructions. The online version is broken into age divisions, please select the one that fits your 4-H Age (age as of 9/1/23). This certification is annual with test out options of 1-3 years. The cost for the face-to-face training will be \$3 and \$12 for the online version. **This training must be completed by July 1, 2024.**
4. ALL 4-H Fair Livestock Entries are due to the Extension Office or submitted on Fair Entry website at the same time as other 4-H Fair entries are due. The entries are due **June 1, 2024** to the Extension Office.
5. The Fayette County **4-H Show** and the **Fayette County Fair Junior and Open** shows require **separate** entries. All Fair Junior Show entries **MUST** be made through the Fayette County Fair Office. 4-Hers wishing to show in the Fayette County Fair Junior Show must make entries from the official Fayette County Fair Book and pay the appropriate fees at the fairgrounds. The Extension Office will not be responsible for junior show entries.
6. Each exhibitor may weigh up to FOUR animals from each species (beef, sheep, goats and swine) for the 4-H Show. This means a member can weigh 4 steers, 4 barrows, 4 sheep wethers, 4 sheep market ewes, 4 goat wethers. 4-H members may then exhibit two market animals in each species (or weight class).
7. All 4-H Market Animal projects (steer, goat wethers, sheep wethers and sheep market ewe lambs) **MUST** be identified and weighed at the county weigh-in to be eligible to exhibit in the Fayette County 4-

H Shows. (Market Steers includes both Beef and Dairy steers.) There will be no early or late weigh-ins of any animal for the Fayette County 4-H Show. If you cannot be there, please make arrangements for someone else to bring your animals. NO EXCEPTIONS!

8. Every 4-Her exhibiting horses/ponies/mules, dogs, or barrows needs to have **OWNERSHIP PAPERS & PHOTOGRAPHS** (one of each side of your animal) on file in the Extension Office by **May 1** of the current 4-H year. Forms can be accessed at <https://extension.illinois.edu/cefi/4-h-fayette-county>.
9. ALL 4-H members taking a livestock project are **REQUIRED** to complete a 4-H Livestock record for the following species: beef, dairy, swine, sheep, poultry, rabbit, meat goat and dairy goat. These records are inspected, along with other health documents, at county 4-H fair check-in to see that they have been started. **Final records must be submitted to the office by the County Awards due date.** Blank copies can be found at the office, or at <https://extension.illinois.edu/cefi/4-h-fayette-county>.
10. 4-H members exhibiting livestock, rabbits or poultry are responsible for **cleaning their own pens after the show.** University of Illinois Extension reserves the right to restrict future participation for those individuals not doing so.
11. There is no entry, stall, or pen fee for the 4-H show.
12. Showmanship contests are divided using the official 4-H Age (age as of Sept. 1, 2023). The Livestock Committee reserves the right to change age breaks dependent upon class size for each species at the Fair.
 - a. Junior, 8-10 years
 - b. Intermediate, 11 – 13 years
 - c. Senior, 14-18 years
 - If class size is small, the Livestock Committee reserves the right to divide the contest into two classes.
 - a. Junior, 8-12 years
 - b. Senior, 13-18 years
13. All market animals must be weighed and shown in the 4-H shows.
14. Livestock must be on the grounds by no later than **12 PM (Noon) on Saturday, July 13th** and **must** remain on the grounds until they are released at the conclusion of the Open/Jr Dairy Show. **Auction animals will be required to stay for the auction.**
15. All livestock exhibited in the 4-H Show must meet State Exhibition Livestock Health Requirements. A copy of these rules is provided in the back of this show book. It is the 4-H'er's responsibility to allow plenty of time for all health papers to be processed by their veterinarian and returned in time for the 4-H show.
16. All livestock exhibitors are expected to check their animals in at the following times:
 - a. Goats & Swine – Saturday at 5:00 PM
 - b. Beef & Sheep – Sunday at 1:00 PM

Weigh-In will take place on Saturday at 5 PM for goats and swine, and on Sunday at 1 PM for beef and sheep. All health certificates, registrations, ownership papers, 4-H livestock records, ect. Will be checked at this time. **Papers should then be kept on the premises (fairgrounds) for the remainder of the fair week in the event that they need to be shown again.**

17. Registration papers are **required** in all purebred classes and must show ownership of the animals in the name of the exhibitor *ONLY* (no partnerships or Farm names) for the period required in the 4-H project. This is so that an individual ID number can be assigned. Certificates from breed association representatives will not be accepted in lieu of the registration papers. **Double registered animals will be allowed entry in only one breed show!** Any registered animals must have been owned by the exhibitor by June 1 of the current year. This will be specified on the animal's registration papers.
18. If you are showing a registered animal in any division, but there is no class listed for that breed, then you must show that animal in the "*All Other Breeds*" Class. Please make sure you have this correct on your entry form.
19. Exhibitors must have their aisles cleaned and cleared. *No tack should be stored in the aisles.* Livestock Superintendents will designate where tack will be allowed. Only the enrolled 4-H member or immediate family members should fit the livestock project(s) for the show. Remember that 4-H is a learning experience for the entire family!
20. In the case that an exhibitor has more than one animal in a class, he/she may ask another *enrolled Fayette County 4-H member to exhibit the additional animal(s).* Parents, Cloverbuds or 4-H'ers from other counties may not assist. Members assisting in showing are expected to have exhibitor's name displayed on their back for clarification for the judges and staff.
21. Exhibition of 4-H projects in local, county, or state exhibits or fairs, is considered a privilege, and is voluntary on the part of the exhibitor. The exhibition of projects provides the 4-H member an opportunity to display their projects, entertain wholesome competition and enjoy an educational/social environment with their peers. With the privilege of exhibition also comes the obligation of abiding by the rules of the respective 4-H projects.
22. **A mandatory livestock meeting will be held in the 4-H show ring at 12:30 PM on Saturday. If you have any scratched or class changes, they must be done at this meeting.** We will pass along any important information for the week and announce any changes that may be applicable.
23. Exhibitors with special needs: At a county level, 4-H leaders shall encourage members to participate in project classes based on their abilities. Special exceptions or modifications to classes shall be made as required to allow the 4-H member a satisfactory experience. Members may advance to the IL State Fair competition, provided they are able to meet the specific class requirements.
24. If livestock needs *any* medication, contact the Show Superintendent, Fair Office, Livestock Committee member, or the Fair vet **BEFORE** administering the medication.
25. The 4-H member must be enrolled in the project and have ownership of animal by the following dates:
 - Steers - by January 1, 2024
 - Barrows – by May 1, 2024 (Swine Ownership Form deadline)
 - Wethers - by May 4, 2024 (Sheep & Goat Weigh-In)

26. Fayette County Farm Bureau Young Leaders will host Master Showmanship on Sunday of fair week. The competition will take place 30 minutes after the conclusion of the 4-H Goat Show. Senior Division: 14 to 18 years old, Junior Division: 8 to 13 years old. More information on the Master Showmanship Contest at the 2024 Fayette County 4-H Show will be shared once available. Winner will have the opportunity to compete at the [Illinois State Fair Master Showmanship Contest on Friday, August 11th](#).
27. Weigh-In animals may be transferred to another immediate family/household member.
28. Horses and Dogs are the only two species that may be leased. Proper forms must be completed.
29. Anyone wishing to exhibit livestock at the Illinois State Fair, must have entries signed by Extension staff and have them postmarked no later than **July 1, 2024**.

2024 LIVESTOCK HEALTH REQUIREMENTS

Please reference the below links for State and County Livestock Health Requirements to show. If you would like a printed copy, please contact Olivia.

State: go.illinois.edu/2024StateLivestockHealthRequirements

County: go.illinois.edu/2024CountyLivestockHealthRequirements

4-H FAIRGROUNDS RULES OF CONDUCT

Any 4-H youth who plans to stay overnight in the 4-H barns during the Fair must read, agree to, and sign the "4-H Code of Conduct" which will be available from your club leader or from the Extension Office. Parents must also sign this agreement. This form **MUST** be turned in to the Extension Office by July 1 or completed during 4-H Online enrollment. 4-Hers under 13 years old must have an adult chaperone (parent preferred) stay overnight with them at the Fairgrounds. The Code of Conduct is completed at the time of registration on ZSuites.

Any violent behavior (fighting, verbal or physical abuse) **will not be tolerated**. The University of Illinois Extension reserves the right to restrict participation in future activities for those individuals who have been removed from an activity for behavior, as outlined in the *"Code of Conduct for 4-H Events and Activities"*. The Fayette County Extension Office and Livestock Committee have the final decision in these situations.



AUCTION OF 4-H ANIMALS RULES & REGULATIONS

ALL 4-H members selling at the Auction **MUST** help clean-up the auction area before AND after the Livestock Auction!

SECTION 1: The auction will include steers, barrows, sheep & goat wethers, rabbits and chickens shown as 4-H projects during the Fayette County 4-H Show. The 4-H member must be enrolled in the project and have ownership of animal by the following dates:

Steers - by January 1, 2023

Barrows - by May 1, 2023 (Swine Ownership Form deadline)

Wethers - by May 4, 2023 (Sheep & Goat Weigh-In)

Steers, barrows, and wethers to be sold at the 4-H Livestock Auction will be identified by county tattoo or ear tag by designated members of the 4-H Livestock Committee at weigh-in.

SECTION 2: Each 4-H'er may sell a maximum of ONE animal in each of the six species, with a **limit of 2** total nominations. Final nominations for auction animals will be made at the livestock weigh-in at the fairgrounds. Grand Champions, Reserve Grand Champions and Rate-of-Gain Champions must sell at the 4-H auction. In the event that the 4-H'er owns multiple winners (Grand, Reserve, and/or Rate-of-Gain Champion), a decision must be made as to which one will sell.

SECTION 3: To be eligible to sell, the animal must:

A. Meet the following weight requirements at the fair:

- Goat wethers: 50-150 pounds
- Sheep wethers: 75-150 pounds
- Steers: 950 pounds or more
- Barrows: 200-285 pounds
- Rabbits: up to but not over 5 pounds each (Market Pen of 3)
- Poultry: Roaster Market Pen - 12 pounds or more; Broiler-Fryer Market Pen - under 12 pounds

****NOTE:** Barrows weighing over 285 pounds will be sold as a 285 pound barrow.

Sheep wethers weighing over 150 pounds will be sold as a 150 pound wether.

B. Meet the following age requirements:

- Meat Goat wethers – born on or after October 1 of previous year
- Lambs – Lambed on or after January 1 of the current year.
- Steers – Calved on or after January 1 of the previous year and not have any permanent teeth.
- Barrows – Farrowed on or after January 15 of the current year.

SECTION 4: The Champion and Reserve Champion in all six species classifications are required to sell in the 4-H Auction (Swine barrow, Sheep wether, Market pen of chickens, Market pen of rabbits, Steer and Goat wether) along with the Champion Rate-Of-Gain in Beef, Goat and Sheep. Champion Market Heifer is not eligible for Auction.

SECTION 5: Sale for future delivery will be allowed for 4-H'ers planning to show the animal at other fairs. *This option must be declared and publicly announced prior to sale.*

- Delivery must be made immediately following those fairs or the week following the State Fair. The 4-H'er assumes complete responsibility for delivering the animal in a physical condition comparable to sale date.
- Original payment will be made to the governing organization based on weights established at the Fayette County 4-H Show. The committee will make payment to the 4-H'er upon proof of delivery. If the animal is not delivered in comparable condition, total payment will be refunded to the buyer.
- A written agreement will be nullified only in such case that the animal wins Grand or Reserve Grand Champion at the Illinois State Fair and is required to be auctioned and slaughtered at that time.

SECTION 6: Sellers are required to arrange delivery of their animal to buyer at no charge at any location within a 50-mile radius of the Fayette County Fairgrounds that is designated by the buyer. Buyer should arrange location within two weeks unless other arrangements are agreed upon by both the buyer and the seller.

SECTION 7: Selling weights will be recorded Sunday night for swine, sheep, goats, and beef. 4-H'ers should be present at weigh in or have someone else do it. Animals will be marked for identification purposes at that time.

SECTION 8: Selling order will be as follows.

- Grand & Reserve Grand Champion Sheep Wethers, followed by other wethers
- Grand & Reserve Grand Champion Barrows, followed by other barrows
- Grand & Reserve Grand Champion Goat Wethers, followed by other wethers
- Grand & Reserve Grand Champion Rabbit Market Pens, followed by other market pens
- Grand & Reserve Grand Champion Poultry Market Pens, followed by other market pens
- Grand & Reserve Grand Champ. Steers, followed by other steers

SECTION 9: At the Auction:

- Animals will be sold on a price per pound basis. *Exception:* rabbits and poultry are sold by the market pen and goat wethers are sold per head.
- Payment for livestock will be accepted immediately following the sale or within two weeks of the auction date.
- A commission charge of 3% will be levied.
- All animals committed to sale must be sold. There is no right to declare "no sale."
- Payment will be made to the Fayette County Livestock Auction, which will make payment to 4-H'er.
- Applicable hauling fees will be paid upon load-out of animal after auction.
- 4-H members must stay with auction animals from 5:30 p.m. until after auction is completed.
- **NO ANIMALS WILL BE RELEASED** until after the conclusion of the Livestock Auction **AND** pens are cleaned.
- Checks will be available for pick-up from the Fayette County Extension Office after September 1 of current year.
- Members MAY NOT LEAVE the auction until their animal has been loaded on the correct truck.

SECTION 10: Members and their families will be considerate of others awaiting their turn in the auction ring. Loud, rude or otherwise disruptive behavior, the early cleaning of stalls to pack up and blocking the lanes for other members will not be tolerated. Animals are released, and members dismissed after the entire auction is over, not just a member's particular section. No member is allowed to pack up and leave until the END of the auction without prior approval.



BEEF CATTLE RULES AND EXHIBIT CLASSES

1. Members wishing to exhibit a market steer must be enrolled and notify the Extension office by Feb. 1.
2. Animals must have proper Health Certificates and meet the requirements of the State of Illinois as found at the end of this Guidebook. Certificates must be available for inspection at the 4-H show.
3. Illinois State Fair rules will preside regarding grooming of livestock for the 4-H county shows: Dying or artificially changing the color of an animal is prohibited. Coloring agents may only be used on the hoof. Powders are not allowed on any part of the animal. Animals may be given a white towel test as they enter the show ring. Cattle are to be shown in their natural conformation. The use of false tail heads is prohibited. The addition of hair, hemp, or any similar substance to any part of an animal is prohibited. No tail ties will be allowed for breeding stock or steers. Exhibitors found breaking the above rules may be asked to immediately exit the show ring.
4. 4-H members wishing to also show in the Fayette County Junior show must make separate entry and pay appropriate fees. The Extension office will not be responsible for these entries.
5. Stall space will be allotted according to the number of exhibitors. Exhibitors showing more than the allotted number will be stalled in "open barns" according to the wishes of the Fayette County Fair Board.
6. All members MUST have their animals broken to lead and be able to control them. Any member's animal that CANNOT be controlled or handled by the 4-H'er will be left tied in the stall or sent home, and the project(s) will be incomplete. This rule is for the safety of the 4-H members as well as the spectators.
7. Each animal entered must have been owned and personally cared for by the exhibitor since the following dates: Steers – January 1 of current year; Cows - January 1 of current year; Heifers - June 1 of current year.
8. The animal(s) may be purebred, grade, or crossbred.
9. No member will be allowed to make more than two entries in each breeding class. A total of 2 steers may be exhibited.
10. Breeding classes are broken down according to the classifications and birth dates.
11. With the division of the calf class, heifer calf class winners will now be included in the champion classes.
12. Exhibitors are allowed to sell only ONE animal per species. The Grand Champion and Reserve Grand Champion steers, and the Champion Rate-of-Gain steer are required to sell in the 4-H Auction, or premiums & trophies must be forfeited. In the event that one exhibitor owns multiple winners (EX: the Grand Champion and the Rate of Gain Champion) then the exhibitor will be required to choose which animal will sell. All steers must weigh a minimum of 950 pounds to be eligible to sell. Steers are to be born on or after January 1 of the previous year. See auction rules for details.
13. All problems should be brought to the attention of the Beef Superintendent or the Extension Office.

BEEF CLASSES

COW & CALF - Calves to be calved after January 1 of the current year (2024)

- Angus
- Hereford
- Simmental
- Shorthorn
- All Other Breeds

SENIOR YEARLING HEIFER - May of two years previous to December of two years previous (2022)

- Angus
- Hereford
- Simmental
- Shorthorn
- All Other Breeds

EARLY JUNIOR YEARLING HEIFER - January through February of previous year (2023)

- Angus
- Hereford
- Simmental
- Shorthorn
- All Other Breeds

LATE JUNIOR YEARLING HEIFER - March through April of previous year (2023)

- Angus
- Hereford
- Simmental
- Shorthorn
- All Other Breeds

SUMMER HEIFER - May of previous year to August of previous year (2023)

- Angus
- Hereford
- Simmental
- Shorthorn
- All Other Breeds

FALL HEIFER - September of previous year to December of previous year (2023)

- Angus
- Hereford
- Simmental
- Shorthorn
- All Other Breeds

2024 HEIFER CALF – Heifer calves born after January of current year (2024).

- Angus
- Hereford
- Simmental
- Shorthorn
- All Other Breeds

2024 BULL CALF – **Beef Bull calves born** after January of current year 2024

(All Dairy Bull or Steer Calves will be shown during the beef show, separate from the dairy bull calf class)

No class champion

- Angus
- Hereford
- Simmental
- Shorthorn
- All Other Breeds

BEEF STEERS - Steers must be calved on or after Jan. 1, 2023

(All steers will be weighed and assigned to classes by weight at fair. Dairy Steers will need to sign up through the Dairy project)

- Extra light (A)
- Light (B)
- Medium (C)
- Heavy (D)
- Extra Heavy (E)

RATE-OF GAIN: Only open to steers, NO Market Heifers. All breeds are eligible for Rate-of-Gain Champion.

BEEF JUNIOR SHOWMANSHIP (8-10)

BEEF INTERMEDIATE SHOWMANSHIP (11-13)

BEEF SENIOR SHOWMANSHIP (14-18)

CAT

Includes members enrolled in Cats

Please follow these rules for the Cat Show:

1. Please bring your animals in a pet taxi. This will give your cat a safe place to hide in if it becomes frightened.
2. All cats are to be in collars and harnesses, on leashes and under direct control of handler AT ALL TIMES.
3. The cats should be able to be handled by the 4-Her and the judge.
4. Each animal entered must have been owned by the member or a member of the immediate family by January 1 of the current year and personally cared for by the exhibitor since May 1 of the current year. **The 4-Her will also be required to provide a health certificate** (request this from your veterinarian at your cat's check-up) and a **record of vaccinations signed by a veterinarian** upon check-in.
5. Make sure your cat is free of fleas and ear mites.
6. A member can exhibit more than one cat, but no member will be allowed to show more than one entry in each class.
7. Cats having registration papers are classified as Purebreds. Any other cats should be shown in the Mixed classes.
8. Kittens are age 6 months to 1 year. Adults are over 1 year. **(Kittens under the age of 6 months are not eligible to show.)**
9. Minimum of 5 entries for show to be held. If the minimum 5 entries is not met, exhibitors will have the opportunity to show a poster project within the animal science general project show to receive the premium for their project.

CONFORMATION CLASSES

Short-Haired Purebred Adult (over 1 year)
Short-Haired Mixed Adult (over 1 year)
Short-Haired Kitten (6 months to 1 year)
Long Haired Purebred Adult (over 1 year)
Long-Haired Mixed Adult (over 1 year)
Long Haired Kitten (6 months to 1 year)

FUN CLASSES

Fun classes, no premium will be paid.
Longest Whiskers
Most Impressive Tail
Smallest (open to cats 1 year or older)
Largest (open to cats 1 year or older)

JUNIOR CAT SHOWMANSHIP (8-12)

SENIOR CAT SHOWMANSHIP (13-18)

DAIRY CATTLE RULES AND EXHIBIT CLASSES

1. All animals must have the proper Health Certificate and must meet the requirements of the State of Illinois. Copies of those rules are found in this Guidebook. **Health Certificates must be available for inspection at the 4-H Show.**
2. All problems should be brought to the attention of the Extension Office staff or the Dairy Superintendent.
3. Each animal exhibited must have been owned and personally cared for by the exhibitor since January 1 of the current year for Cows or June 1 of current year for Heifers and Calves.
4. All members **MUST** have their animals broken to lead and be able to control them. Any member's animal that **CANNOT** be controlled or handled by the 4-Her will be left tied in the stall or sent home, and the project(s) will be incomplete. This rule is for the safety of the 4-H members as well as the spectators.
5. The animals may be purebred or grade.
6. No member will be allowed to make more than two entries in each class.
7. Livestock must be on the grounds by no later than **12:00 noon on Saturday, July 13th** and **must** remain for 72 hours. Please note the Dairy Show time is tentative to change based on the discretion of the Livestock Committee.
8. Any animal in milk must show in the cow class.
9. 4-H members wishing to show in the Fayette County Junior show must make separate entry and pay appropriate fees. The Extension office will not be responsible for these entries.
10. The Dairy Steer and Dairy Bull or Steer Calf classes will be shown during the beef show.

DAIRY CLASSES

JUNIOR HEIFER CALF – Born December 1 of the previous year (2023)

SENIOR HEIFER CALF – Born September 1 to November 30 of the previous year (2023)

LATE YEARLING HEIFER – Born March 1 to August 31 of the previous year (2023)

EARLY YEARLING HEIFER – September 1 of two years previous (2022) to February 28th of the previous year (2023)

COWS – 2 & 3 year old

COWS – 4 years old and over

DAIRY BULL OR STEER CALF – Born after January 1 of the current year (2024)

(All Dairy Bull or Steer Calves will be shown during the beef show, separate from the beef bull calf class)

No class champion

DAIRY STEERS – Born on or after January 1 of the previous year (2023)

(All steers will be weighed and assigned to classes by weight at fair. **Dairy Steers** are shown during the beef show)

- Light (A)
- Medium (B)
- Heavy (C)

RATE-OF GAIN: Only open to steers, NO Market Heifers. All breeds are eligible for Rate-of-Gain Champion.

DAIRY JUNIOR SHOWMANSHIP (8-12)

DAIRY SENIOR SHOWMANSHIP (13-18)

DOG

For youth enrolled in Dogs

Please follow these rules for the Dog Show:

1. The State of Illinois requires that all dogs must be vaccinated for distemper and rabies. Shot records and a health certificate must be obtained from the veterinarian and presented at check-in. Sick animals will not be allowed to show. (Dogs in season will not be permitted to show.)
2. All dog projects must check in 30 minutes prior to the start of the show. All vaccination records and health certificates must be available at that time, or the exhibitor will be disqualified.
3. All members are strongly encouraged to attend a dog workshop if offered.
4. All dogs must be leashed. No chain leashes, flexy, or retractable leashes. No electronic collars are allowed. Other types of collars like the prong collar, if approved by the Dog Superintendent, can be used at the local show but will not be eligible to receive a qualifying score. (Slip chain "training" or pinch/prong collars are not allowed at the Illinois 4-H Dog Show.)
5. The following will result in the disqualification of the exhibitor and dog:
 - The dog bites the judge.
 - The dog snips at the judge without reprimand from the exhibitor.
 - The dog urinates or defecates while in the show ring.
6. 4-H members must be responsible for primary care and training of their dog since May 1 of the current 4-H year. Dogs do not have to be purebred or registered. Each 4-H member must submit a current **Fayette County 4-H Dog Certificate of Ownership Form** with 2 attached photos of their dog (one of each side) by **May 1** of the current year. (If the 4-Her's does not own the dog, he/she must have a current Fayette County 4-H Dog Certificate of Lease Form with 2 attached photos of the dog, one of each side, stating that he/she has trained, groomed, and cared for the dog since May 1 of the current year.) This rule may be waived in the event of illness or death of a dog. Dog Ownership form can be found at the office or online at <https://extension.illinois.edu/cefi/4-h-fayette-county>.
7. A 4-H member may enter only one dog per class. A 4-H member may show a maximum of two dogs. Each dog will require a separate 4-H Dog Ownership/Lease Form.
8. Waste Management: Anyone not cleaning up after their dog will be excused from the show.
9. It is highly recommended that a 4-Her repeat each obedience level until they obtain a qualifying score at the county level before moving up to next obedience level. This is only a recommendation, and it is up to the 4-Her to decide what level they want to work on. (Refer to information below on Advanced Novice 1 and 2 classes.)
10. Any youth enrolled in the 4-H Dog project must also complete Quality Assurance & Ethics Certification (QAEC) prior to making county show entries. This training is required once during a 4-H member's career. This free online training is available at <http://web.extension.illinois.edu/qaec/>
11. It is recommended that dogs have the Canine Good Citizen certification before showing in Obedience or Rally classes. CGC will be required at the state level beginning in 2025.

DOG PRE-BEGINNER OBEDIENCE (not eligible to advance to the Illinois 4-H Dog Show)

This class is for exhibitors who are new to showing dogs. Be prepared to go through the exercises requested by the judge.

Minimum age for dog to begin is six months.

1. Heel on leash
2. Figure 8 on leash
3. Stand for Exam (at dog's side)
4. Long Sit (30 seconds)
5. Recall on leash

DOG OBEDIENCE

Be prepared to go through the exercises requested by the judge. To advance to the next level, the 4-H member must obtain the points listed for each class. Minimum age for dog to begin is six months. Exhibitors will be divided into the following classes:

Beginner Novice I Class - (for inexperienced handlers with inexperienced dogs)

1. Heel on Leash (forward, halt, right turn, left turn, about turn, slow, normal and fast). The last order signifies that the handler and dog must break pace. These orders will be given by utilizing posted signs - Maximum points 40
2. Figure Eight (on leash) - Maximum points 40
3. Sit for Exam (on leash) - Maximum points 40
4. Sit Stay (walk around ring) - Maximum points 40
5. Recall (off leash front/no finish) - Maximum points 40

Beginner Novice II Class - (for experienced handlers with inexperienced dogs or experienced dogs with inexperienced handlers)

1. Heel on Leash (forward, halt, right turn, left turn, about turn, slow, normal and fast). The last order signifies that the handler and dog must break pace. These orders will be given by utilizing posted signs - Maximum points 40
2. Figure Eight (on leash) - Maximum points 40
3. Sit for Exam (on leash) - Maximum points 40
4. Sit Stay (walk around ring) - Maximum points 40
5. Recall (off leash front/no finish) - Maximum points 40

Preferred novice Class, Advanced Novice 1 Class, Advanced Novice 2 Class, Graduate Novice Class, Preferred Open Class, Open Class, Graduate Open Class, Preferred Utility Class, Utility Class (for exhibitors who have scored at least 170 points in a previous class in a previous year) – Information for these classes to be provided upon need/request.

RALLY OBEDIENCE

1. Dog/Handler team must receive a qualifying score of 70 out of 100 to compete at the state level.
2. The event will be timed. In event of a tie score, the fastest time will break the tie.
3. Rally rings will be at least 2000-3000 square feet with a minimum width of 30 feet.
4. Unless otherwise noted, handler may speak to the dog, pat their leg, or clap their hands to encourage.
5. Exhibitor must earn three qualifying scores before moving up to the next Rally level.

Rally Novice

10-15 signs are used (not including start and finish). 3-7 of the signs must be “stationary” signs. Performed on leash.

Rally Intermediate, Rally Advanced, and Rally Excellent – Information for these classes to be provided upon need/request.

DOG CARE (not eligible to advance to the Illinois 4-H Dog Show)

Members are judged on grooming and knowledge of dog care and grooming. Grooming by professional dog groomers is discouraged. No puppies under six weeks of age (as of March 1) are allowed.

- Junior Dog Care (for handlers ages 8 to 13 as of 3/1/24).
- Senior Dog Care (for handlers ages 14 and older as of 9/1/23).

SHOWMANSHIP

Exhibitors will be judged on handling skill, knowledge of breed standards of their dog, dog show terminology, and elementary dog anatomy. Dogs will be judged on cleanliness, general health, grooming, and teamwork with their handler. Classes will be divided into Junior (ages 8 to 13) & Senior (ages 14 and older).

- Junior Showmanship (for handlers age 8 to 13 as of 9/1/23)
- Senior Showmanship (for handlers age 14 and older as of 9/1/23)

Fun Classes (no premiums)

- Costume Class

Goats (Dairy, Meat) RULES AND EXHIBIT CLASSES

1. All animals must have proper Health Certificate and meet the requirements of the State of Illinois. (The requirements and/or tests are to be performed by approved veterinarian). Health certificates must be available for inspection at the 4-H show.
 2. Dairy Goats entered must have been owned and personally cared for by the exhibitor from the following dates: Wether—by weigh in date, Kids/Yearlings not in milk (under 1 year) - June 1 of the current year; Does over 1 year - January 1 of the current year
 3. Dairy and Dairy-Cross Goats are not allowed to have horns, per American Dairy Goat Association.
 4. Meat Goats entered must have been owned and personally cared for by the exhibitor from the following dates: Wethers – by weigh-in date, Kids/Yearlings not in milk – May 15 of the current year
 5. The animals may be purebred, grade or crossbred.
 6. Animals are to be *in the ring* immediately after the class is called, or they will not be allowed to show in that class. All animals must be clearly identified by identifiable tag number. Members must list the specific tag numbers for each animal in each class at check-in.
 7. Animals shown in the Mother-Daughter Class must have been shown in individual classes during the show. Daughter/kid is to be born current year. Only one entry in the Mother/Kid Classes will be allowed.
 8. Animals will be classified as the following: Meat Breeding (Registered and Commercial), Dairy Breeding (Registered and Commercial), Pygmy, and Market. Registered animals should be those that have registration papers and commercial are those without. If you have a goat that has been crossed between dairy and meat species, they will be placed in the Commercial class based off of their predominant characteristics.
- *Note from Kasey – Please note that goat classes have been reorganized within this last year. All goat classes remain an option but have been organized into Meat (Registered and Commercial), Dairy (Registered and Commercial), Pygmy, and Market. If you have questions about where to place your entry, please reach out to Olivia for guidance.
9. ENTRY LIMIT: Members will be allowed two entries per class EXCEPT in the Mother-Daughter Class. **Only one entry in the Mother-Daughter Classes will be allowed.** 4-H'ers who have more than one entry in a class must find ONE 4-H member to be their DESIGNATED HELPER throughout the entire goat show. Helpers must be 4-H members; parents and Cloverbuds are not allowed to show.
 10. Any animal that cannot be handled by the exhibitor may be excused from the ring, at the judge's discretion.
 11. Goat wethers must be banded *at weigh-in time*. Goat wethers will be assigned to classes by weight.
 12. 4-H members wishing to show in the Fayette County Junior show must make separate entry and pay appropriate fees. The Extension office will not be responsible for these entries.
 13. Exhibitors are allowed to sell only ONE animal per species. The Grand Champion and Reserve Grand Champion wethers, and the Champion Rate-of-Gain wether are required to sell in the 4-H Auction, or premiums & trophies must be forfeited. In the event that one exhibitor owns multiple winners (EX: the Grand Champion and the Rate of Gain Champion) then the exhibitor will be required to choose which animal will sell. See auction rules for details.

GOAT CLASSES

MARKET CLASSES

All wethers will be assigned to weight class upon weigh-in at the fair and be in contention for Rate of Gain.

- Meat – light, medium, heavy
- Dairy – light, medium, heavy
- Commercial – light, medium, heavy
- Rate of Gain – (one chosen from all combined)

MEAT BREEDING CLASSES

- Registered Meat Doe Kid 0-6 months
- Registered Meat Doe Kid 6-12 months
- Registered Meat Doe Kid 12-24 months
- Registered Meat Doe 2 years
- Registered Meat Doe 4 years/up
- Registered Meat Mother-Daughter Pair
- Commercial Meat Doe Kid 0-6 months
- Commercial Meat Doe Kid 6-12 months
- Commercial Meat Doe Kid 12-24 months
- Commercial Meat Doe 2 years
- Commercial Meat Doe 4 years/up
- Commercial Meat Mother-Daughter Pair

DAIRY BREEDING CLASSES

- Registered Dairy Doe Kid 0-6 months
- Registered Dairy Doe Kid 6-12 months
- Registered Dairy Doe Kid 12-24 months
- Registered Dairy Doe 2 years
- Registered Dairy Doe 4 years/up
- Registered Dairy Mother-Daughter Pair
- Commercial Dairy Doe Kid 0-6 months
- Commercial Dairy Doe Kid 6-12 months
- Commercial Dairy Doe Kid 12-24 months
- Commercial Dairy Doe 2 years
- Commercial Dairy Doe 4 years/up
- Commercial Dairy Mother-Daughter Pair

PYGMY GOAT CLASSES

- Pygmy Doe Kid, under 12 months
- Pygmy Doe, 13 months and up

4-H SHOWMANSHIP/CLEAN PEN CLASSES

- Clean Pen
- Junior Showmanship (8-10 4-H age)
- Intermediate Showmanship (11-13 4-H age)
- Senior Showmanship (14-18 4-H age)

HORSE RULES AND EXHIBIT CLASSES

1. Each exhibitor must comply with the general eligibility rules, which are listed in the front of the 4-H Handbook.
2. 4-H members wishing to show in the Fayette County Junior show must make separate entry and pay the appropriate fees. The Extension Office will not be responsible for these entries.
3. All problems should be brought to the attention of the Horse and Pony Superintendent or Extension Office staff.
4. Project animals should be owned or leased and personally cared for by the 4-H member by **May 1**.
5. ALL 4-H members taking a horse project are **REQUIRED** to complete the following records:
 - A 4-H Horse Lease Form or Ownership form showing 2 pictures of your horse (one of each side) must be submitted to the Extension office by **May 1**. Horse Ownership Forms found at the office or online at <https://extension.illinois.edu/cefj/4-h-fayette-county>.
 - A 4-H Livestock record must be submitted at the county 4-H fair check-in to see that they have been started. Final records must be submitted to the office by the County Award due date.
 - Proof of Coggins test must be submitted at the time of exhibition at the 4-H Fair.
6. If you are planning to show at the State Fair Junior Horse Show, copies of papers and photos must be attached to the official State Fair Junior Show entry forms due June 1 of the current year.
7. No member will be allowed to make more than two entries in each class. Double entries are not permitted in showmanship, or pleasure classes. (A given animal can be entered only once per class.)
8. Horses are over 56"; Ponies are 56" & under.
9. Your attire reflects your equine knowledge. Suggested attire:
 - Western: Boots, hat, jeans, and long-sleeve collared shirt. Chaps and spurs optional. **NO** T-shirts or tank tops.
 - English/Hunt: Riding /field boots or Paddock boots, helmet, breeches, and jacket. Riding crops and English spurs are permitted.
 - Speed classes: Boots, jeans hat (per Rodeo Association rules) and collared shirt (may be long or short sleeve.) **NO** sleeveless shirts, T-shirts, tank tops, etc.
10. All 4-H members are **REQUIRED** to wear properly fitted ASTM or SEI standard F1163 (or above) certified equestrian helmet whenever mounted or driving at all 4-H horse and pony events, shows, activities, or practices. Original tags must be present in all approved helmets. The 4-H member is responsible to see that this specified headgear is properly fitted with the approved harness fastened snugly in place whenever mounted. Helmet policies apply to all county, area, and state 4-H horse and pony events, shows and activities. *Protective helmets are recommended for all riders and drivers at all times. It is recommended that all adults working with 4-H members model the desired youth behavior by also wearing protective helmets whenever mounted or driving.*
11. All tack should follow AQHA Rules. A copy of the guidelines for Illinois horse shows which includes the tack rules is available from the Extension office. Members with tack not meeting AQHA safety rules could be subject to dismissal at the 4-H Show.
12. Only authorized personnel are allowed in announcer's stand.
13. Disorderly conduct by participants or spectators will not be tolerated and will be grounds for dismissal.

14. The PA system is used as an aid to the show and a courtesy to participants. It cannot be, and is not expected to be, heard from all areas surrounding the ring. Therefore, failure to hear the class call is not an acceptable excuse to miss a class.
15. Do not ride horses to the food stands! If your horse makes a mess in a high traffic area, YOU are responsible for cleanup!
16. Horses should be kept at walking gait outside the arena if around other horses, riders, or spectators. Horses should be walked to the gate.
17. 4-Hers are encouraged to read and follow the Rules for Illinois Horse Shows. A printed copy of the 50-page book is available from the Extension Office.

HORSE AND PONY CLASSES

HALTER CLASSES

- **Halter (Conformation)** - Mares & Geldings over 56"
- **Showmanship I** (ages 8-13) - English or Western
- **Showmanship II** (ages 14-19) - English or Western
- **Pony Halter (Conformation)**– Ponies (56" and under)
- **All Other Halter** – Mares & Geldings (donkeys, miniature, heavy horses)

RIDING CLASSES

- **Walk-Trot Pleasure** (Beginners in their first 3 years of Horse Project) – Western **OR**
- **Western Pleasure** (Exhibitors with more than 3 years' experience) – Western Walk, trot, & canter
- **Country Pleasure** - Western or English Tack - walk & favorite gait
- **Country Pleasure** – Western Gaited - walk & favorite gait (gaited horses only)
- **Horsemanship** – Western (ages 8-13)
- **Horsemanship** – Western (ages 14-19)
- **Pony Horsemanship**– Western
- **Trail Class I** (Beginner) – Exhibitors in their first 3 years of the Horse project
- **Trail Class II** (Advanced) – Exhibitors with more than 3 years of experience

FUN CLASSES No premiums Paid

- **Costume Class** –Rider and animal both dress up for judging. *Will exhibit while trail course is being set up*
- **Egg and Spoon Class** –Last one with an egg wins!
- **Pole Class** - A timed event through 6 poles, each 21 feet apart, all placed in a straight line
- **Barrels** – A timed event around three barrels in a clover leaf pattern

POULTRY RULES AND EXHIBIT CLASSES

1. Each exhibitor must comply with the general eligibility rules, which are listed in the front of the 4-H Handbook.
2. All problems should be brought to the attention of the poultry superintendent or the Extension Office staff.
3. Each animal entered must have been personally owned & cared for by the exhibitor by June 1 of the current year.
4. The animals may be purebred, grade, or crossbred.
5. Each exhibitor is allowed to make two entries per class. Members are only paid on one entry per class.
6. 4-H members wishing to show in the Fayette County Junior show must make separate entry and pay the appropriate fees. The Extension Office will not be responsible for these entries.
7. No health tests are required for poultry exhibiting in a one-day show.
8. Turkeys, ducks, geese, guineas, pheasants, quail, peafowl, and pigeons must be of breeding age.
9. All A rating market pens will be eligible for sale at auction. Grand and Reserve Grand market pens must sell. In the event both winners are owned by the same exhibitor, that exhibitor will be required to choose which market pen to sell.
10. No parents or visitors will be allowed in the building during judging.

CHICKEN CLASSES

Breeding Pen, One Cockerel and Two Pullets

- Standard Breeds
- Bantam Breeds

Single Cockerel (male hatched during current year)

- Standard Breeds
- Bantam Breeds

Single Pullet (female hatched during current year)

- Standard Breeds
- Bantam Breeds

Adult Trio, One Cock & Two Hens*

- Standard Breeds
- Bantam Breeds

Single Cock* (male hatched prior to current year)

- Standard Breeds
- Bantam Breeds

Single Hen* (female hatched prior to current year)

- Standard Breeds
- Bantam Breeds

**denotes county class*

POULTRY MARKET CLASSES

Roaster Market Pen: Shall consist of 3 cockerels or 3 pullets, any breed, weight of each bird shall be over 4 pounds, not to exceed 8 pounds, with ¼ pound allowance for all three birds.

Broiler-Fryer Market Pen: Shall consist of 3 cockerels or pullets, any breed, weight of each bird shall be 4 pounds and under

OTHER FOWL CLASSES

TURKEY

- Hen
- Tom

PIGEONS

- Female
- Male
- Pair

GUINEAS

- Pair

PHEASANTS

- Pair

QUAIL

- Pair

PEAFOWL

- Pair

DUCK

- Hen
- Drake
- 1 Drake/2 Hens

GEESE

- Hen
- Gander
- 1 Gander/2 Hens

JUNIOR POULTRY SHOWMANSHIP (8-10)

INTERMEDIATE POULTRY SHOWMANSHIP (11-13)

SENIOR POULTRY SHOWMANSHIP (14-18)

The following projects will be judged at judge's discretion:

EGG PRODUCTION - Display record sheet and 1 dozen eggs.

EMBRYOLOGY - Display record sheet. Describe, in display or written report, the development of chick from embryo to hatching.

RABBITS RULES AND EXHIBIT CLASSES

1. Each exhibitor must comply with the general eligibility rules, which are listed in the front of the 4-H Handbook.
2. All problems should be brought to the attention of the Rabbit Superintendent or the Extension Office.
3. Each animal must be owned and personally cared for by the exhibitor by June 1 of the current year.
4. Animals may be purebred, grade, or crossbred.
5. No member will be allowed to make more than two entries in each class.
6. Exhibitors may furnish their own cages for exhibition purposes. Cages at the fairgrounds cannot be reserved. Cages are for the 4-H animals first.
7. Exhibitors unable to be present during judging must contact the superintendent or the Extension Office. These individuals must have another current Fayette County 4-H member present on their behalf during the judging.
8. To show, ALL rabbits must have a tattoo in left ear. (A.R.B.A. requirement).
9. 4-H members wishing to show in the Fayette County Junior show must make separate entry and pay the appropriate fees. The Extension Office will not be responsible for these entries.
10. NO rabbits to be sold in the auction will be re-tattooed.
11. All rabbits will be showing in a 4 class and a 6-class fashion, according to A.R.B.A. standards.
12. All crossbred rabbits will be shown as 6 class rabbits.
13. Exhibitors are allowed to sell one A rating market pen. Grand and Reserve Grand market must sell. In the event

both winners are owned by the same exhibitor, that exhibitor will be required to choose which market pen to sell.

14. No guardians will be allowed in the judging area while judging is in progress.

Classifications of Rabbits

AG = All Groups

AV = All Varieties

4 Class

American Fuzzy Lop AG	Florida White	Lionhead	Rhineland
American Sable	French Angora – AG	Mini Lop – AG	Satin Angora - AG
Belgian Hare	Harlequin – AV, AG	Mini Rex – AV	Silver – AV
Britannia Petite – AV	Havana – AV	Mini Satin	Silver Martin – AV
Dutch – AV	Himalayan – AV		Standard Chinchilla
Dwarf Hotot	Holland Lop – AG	Netherland Dwarf – AG	Tan- AV
English Angora – AG	Jersey Wooly – AG	Polish – AV	
English Spot – AV	Lilac	Rex—A	

6 Class

American – AV	Chinchilla, Giant	French Lop	Satin – AV
Beveran – AV	Cinnamon	Giant Angora	Silver Fox
Californian	Cream D'Argent	Hotot	
Checkered Giant – AV	English Lop – AG	New Zealand – AV	
Chinchilla, American	Flemish Giant – AV	Palomino – AV	

RABBIT CLASSES

4 CLASS

- Junior Doe (3 - 6 months)
- Senior Doe (6 months & over)
- Junior Buck (3 - 6 months)
- Senior Buck (6 months & over)

6 CLASS

- Junior Doe (3 - 6 months)
- Intermediate Doe (6-8 months)
- Senior Doe (8 months & over)
- Junior Buck (3 - 6 months)
- Intermediate Buck (6 - 8 months)
- Senior Buck (8 months & over)

Market Pen – Pen of 3; may be of any sex; must not exceed 5.5 lbs. each.

Single Fryer – 1 rabbit; may be of any sex; must not exceed 5.5 lbs.

JUNIOR RABBIT SHOWMANSHIP (8-10)

INTERMEDIATE RABBIT SHOWMANSHIP (11-13)

SENIOR RABBIT SHOWMANSHIP (14-18)

SHEEP RULES AND EXHIBIT CLASSES

1. All animals must have the proper Health Certificate and must meet the requirements of the State of Illinois. The rules are found in the back of this Guidebook. Health Certificates must be available for inspection at the 4-H show. All sheep must have proper scrapies tags as stated states rules.
2. All problems should be brought to the attention of the Sheep Superintendent or the Extension Office staff.
3. Each animal exhibited must have been owned and personally cared for by the exhibitor since the weigh-in date of current year.
4. Animals may be purebred, grade, or crossbred.
5. No member will be allowed to make more than two entries in each class.
6. Breeding classes will be broken down according to their age division.
7. 4-H members wishing to show in the Fayette County Junior show must make separate entry and pay appropriate fees. The Extension Office will not be responsible for these entries.
8. Illinois State Fair rules will preside regarding grooming of livestock for the 4-H county shows: Artificial coloring of sheep will not be allowed.
9. Exhibitors are allowed to sell only ONE animal per species. The Grand Champion and Reserve Grand Champion wethers and the Champion Rate-of-Gain wether are required to sell in the 4-H Auction, or premiums & trophies must be forfeited. In the event that one exhibitor owns multiple winners (EX: the Grand Champion and the Rate of Gain Champion) then the exhibitor will be required to choose which animal will sell. See auction rules for details.

SHEEP CLASSES

EWE & LAMB - Ewe or wether born on or after Jan. 1 of current year

- Registered Breeds
- All Other Commercial

YEARLING EWE - Born on or after Jan. 1 of the previous year

- Registered Breeds
- All Other Commercial

EWE LAMB (JUNIOR EWE) - Born on or after Jan. 1 of current year

- Registered Breeds
- All Other Commercial

MARKET EWE LAMB – Born on or after Jan. 1 of current year

WETHER - born on or after Jan. 1 of current year

- All Other Commercial

ALL Market Ewe Lambs and Commercial Junior Ewes will be weighed and assigned to light/heavy weight classes. ALL wethers will be assigned to light/medium/heavy weight classes

PEN OF WETHERS (Pair of wethers, both owned by same exhibitor)

- All Other Commercial

SHEEP RATE-OF-GAIN: All sheep wethers compete for title

JUNIOR SHOWMANSHIP (8-10)

INTERMEDIATE SHOWMANSHIP (11-13)

SENIOR SHOWMANSHIP (14-18)

SWINE RULES AND EXHIBIT CLASSES

1. Each swine exhibitor is responsible for reading the General Eligibility Rules, Auction Rules & Health Regulations. All problems should be brought to the attention of the Swine Superintendent or the Extension Office staff.
2. Swine entries may be purebred or crossbred and must have been owned and cared for by the exhibitor by **May 1st** (Ownership Deadline).
3. Purebred entries with individual registration papers will be shown in the purebred classes. You must have registration papers on hand. Crossbred entries will be shown in the commercial class. Purebred entries that have no classes will be shown in the All Other Class.
4. Breeding stock must have been farrowed on or after January 1 of the current year. All barrows must be born on or after **January 1** of the current year.
5. Exhibitors may make no more than two entries in each class. Exhibitors may show 2 crossbred gilts in each weight class with a maximum of 4 in the crossbred division. All crossbred gilts will be identified. Exhibitors may show two crossbred barrows. Four barrows may be tagged in the spring but only two can be exhibited per weight class.
6. **ALL Barrows must be tagged by May 1st and have Ownership forms for each tagged barrow submitted to the Fayette County Extension office with 2 pictures (one of each side) attached by May 1st.** One picture must have Fayette County 4-H assigned swine tag visible in the ear. Ownership Forms can be found at the office or online at <https://extension.illinois.edu/cefi/4-h-fayette-county>.
7. 4-H members wishing to show in the Fayette County Junior show must make separate entry and pay appropriate fees. The Extension office will not be responsible for these entries.
8. The minimum weight to sell at auction is 200 lbs.; maximum weight *for sale price* is 285 lbs.
9. Hogs need to be in their pens by 12 PM (noon) on Saturday.
10. Hogs will be released after the Livestock Auction.
11. Exhibitors are allowed to sell only ONE animal per species. The Grand Champion and Reserve Grand Champion barrows are required to sell in the 4-H Auction, or premiums & trophies must be forfeited. In the event that one exhibitor owns multiple winners (EX: the Grand Champion) then the exhibitor will be required to choose which animal will sell. See auction rules for details.
12. Premises Identification numbers will be required for all Junior Department Barrow entries to the Illinois State Fair. This is being required by the packing house(s) that process the barrows from the State Fair; since the show is terminal, the Premises ID number will be required.
13. There will be NO Rate-of-Gain contest for Fayette County 4-H Swine Show.

SWINE CLASSES

PUREBRED CLASSES - (Must show registration papers)

- **PUREBRED JANUARY GILT:** Gilt born in January of the current year
- **PUREBRED FEBRUARY GILT:** Gilt born in February of the current year
- **PUREBRED BARROW**
 - Light
 - Medium
 - Heavy

COMMERCIAL/CROSSBRED

- **Gilt**
 - Light
 - Medium
 - Heavy
- **Barrow**
 - Extra Light
 - Light
 - Medium
 - Heavy
 - Extra Heavy

- ✓ *All purebred barrows will be assigned to one of two weight classes following the weigh-in at the fair.*
- ✓ *All commercial/crossbred gilts will be assigned to one of four weight classes following the weigh-in at the fair.*
- ✓ *All commercial/crossbred barrows will be assigned to one of four weight classes following the weigh-in at the fair.*

JUNIOR SHOWMANSHIP (8-10)

INTERMEDIATE SHOWMANSHIP (11-13)

SENIOR SHOWMANSHIP (14-18)

Notes

Contact Us

FAYETTE COUNTY EXTENSION OFFICE

University of Illinois Extension
118 N. Sixth St.
Vandalia, IL 62471
Phone: 618-283-2753
FAX: 217-327-7775

Office Hours:

Monday-Friday
8 a.m. to 4:30 p.m.
Closed 11:30 a.m. to 12:30 p.m.

STAFF

Olivia Snyder

Extension Program Coordinator, 4-H
omsnyder@illinois.edu

Chrissy Caudle

Office Support Assistant
ccaudle@illinois.edu

Patty Edwards

Community Worker, SNAP-Ed

Kasey Kemme

Extension Educator, 4-H Youth Development

Jessica Wells

County Extension Director

Michelle Fombelle

Extension Educator, SNAP-Ed

WEBSITES

Unit 21 Extension: <https://extension.illinois.edu/cefj>
4-H Enrollment: 4h.zsuite.org
4-H Fair Entries: fairentry.com

FACEBOOK

@FayetteCountyIL4H